





Français 3
English 25

Actionneur électrique Electric actuator VR • VS • VT

Anticondensation
intégrée

Anticondensation
heater

Facteur de marche
50%
Duty cycle

Indice de protection
IP68
Enclosure protection

25Nm

2400Nm

Système de sécurité
**FAIL
SAFE**
Security system

Positionnement
POSI
Positioning

3
POSITIONS

AXMART[®]

BLUETOOTH[®]

Description

Electric actuators, aluminium housing and polyamide UL94V0 or aluminium (option) cover with manual override by external shaft or hand wheel, for torques from 25 to 300Nm and in accordance with CE-ROHS-REACH Directives.



VR • VS • VT

Version	Page / External ref.
standard VR • VS	25
standard VT	29
VR • VS with FAILSAFE security unit	33
VR • VS with positioning solution	36
VR • VS 3-position	39
VR • VS POSI-SAFE (FAILSAFE + positioning)	42
VR • VS 3-POSITION-SAFE (FAILSAFE + 3-position)	44
« Powered by AXMART® ». Bluetooth® connection for control and programming	DSBA3302
Version of VR • VS • VT for every marine application: 15-year warranty high durability coating ¹⁾	—
Pulse control (500ms) ¹⁾	—
Applications with vibrations ¹⁾	—

¹⁾On request.

VR • VS technical datas

Visual position indicator	Modular (VR) et spherical (VS)
Control	On-Off or 3-modulating points
Voltages	15V to 30V AC (50/60Hz) & 12V to 48V DC • 100V to 240V AC (50/60Hz) & 100V to 350V DC • 400V 3-phase (50/60Hz)
Duty cycle	Service S4 - 50% (IEC34 standard)
Torque limiter	Software
Serial connection	RS485
Number of starts / hour ²⁾	150
Feedback relay	Failure (torque, temperature ...)
Anti-condensation heater	Self-regulated
Drive nut	Star
Removable adaptation plates (ISO5211)	VR: F05-F07 • VS: F07-F10
Number of limit switches	4 adjustable switches (5A max.)
Secured manual override	Declutching system and external shaft (VR) • wheel (VS)
Mechanical travel stops	90° (180° et 270° versions without mechanical travel stops)
Electric connection	2 ISO M20
Temperature	-20°C à +70°C (FAILSAFE actuators: -10°C to +40°C)
Enclosure	IP68
Weight	VR: 3,1Kg to 4,4Kg • VS: 5,1Kg to 6,4Kg
Warranty ³⁾	3-year warranty or 50 000 actuations

²⁾ Recommended use, see instructions notice.

³⁾ Tested on testing bench in the worst conditions (maximal torque and duty rating).

Options

Card with two extra limit switches (EFC.2)

100 / 1000 / 5000 / 10000 Ohms feedback potentiometer (EPR.B)

0-10V, 0-20mA or 4-20mA transmitter (EPT.C) ⁴⁾

1 or 2 connector M12 3P+T (ECM.1 or ECM.2)

⁴⁾ Specify the model.



Please consider 1.5 safety factor (and 2.0 safety factor for POSI version) when sizing the actuator

Standard range

Code	Star drive nut Connection	Torque	Voltage supplies	Power	Operating time
VR25.70A.G00	17 F05/F07	25Nm	100V to 240V 50/60Hz (100V to 350V DC)	45W	7s
VR25.70B.G00	17 F05/F07	25Nm	15V to 30V 50/60Hz (12V to 48V DC)	45W	7s
VR45.70A.G00	17 F05/F07	45Nm	100V to 240V 50/60Hz (100V to 350V DC)	45W	15s
VR45.70B.G00	17 F05/F07	45Nm	15V to 30V 50/60Hz (12V to 48V DC)	45W	15s
VR75.70A.G00	17 F05/F07	75Nm	100V to 240V 50/60Hz (100V to 350V DC)	45W	20s
VR75.70B.G00	17 F05/F07	75Nm	15V to 30V 50/60Hz (12V to 48V DC)	45W	20s
VS100.90A.G00	22 F07/F10	100Nm	100V to 240V 50/60Hz (100V to 350V DC)	45W	15s
VS100.90B.G00	22 F07/F10	100Nm	15V to 30V 50/60Hz (12V to 48V DC)	45W	15s
VS150.90A.G00	22 F07/F10	150Nm	100V to 240V 50/60Hz (100V to 350V DC)	45W	30s
VS150.90B.G00	22 F07/F10	150Nm	15V to 30V 50/60Hz (12V to 48V DC)	45W	30s
VS300.90A.G00	22 F07/F10	300Nm	100V to 240V 50/60Hz (100V to 350V DC)	45W	60s
VS300.90B.G00	22 F07/F10	300Nm	15V to 30V 50/60Hz (12V to 48V DC)	45W	60s

400V 3-phase range

Code	Star drive nut Connection	Torque	Voltage supplies	Power	Operating time
VR25.709.R00	17 F05/F07	25Nm	400V TRI	52W	10s
VR45.709.R00	17 F05/F07	45Nm	400V TRI	52W	10s
VR75.709.R00	17 F05/F07	75Nm	400V TRI	52W	15s
VS100.909.R00	22 F07/F10	100Nm	400V TRI	135W	10s
VS150.909.R00	22 F07/F10	150Nm	400V TRI	135W	20s
VS300.909.R00	22 F07/F10	300Nm	400V TRI	135W	35s

Dimensions

Type : VR

Type : VS

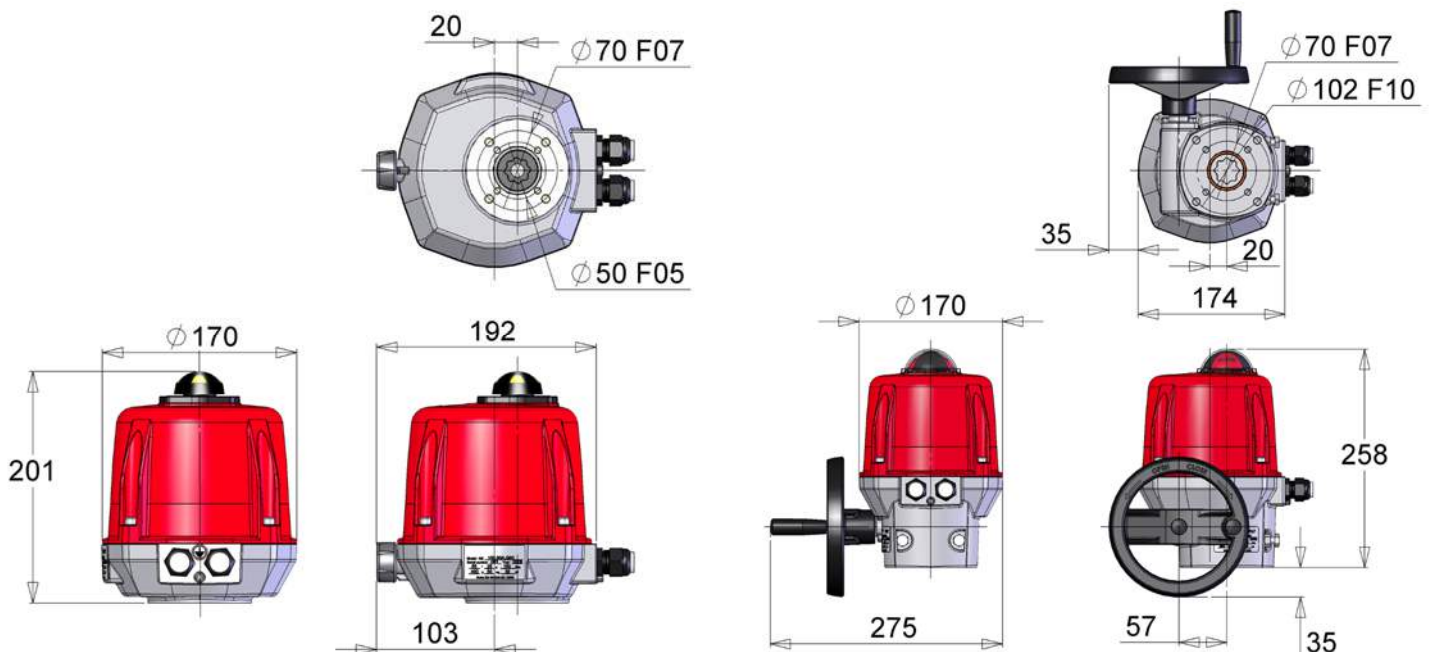

Please consider 1.5 safety factor (and 2.0 safety factor for POSI version) when sizing the actuator

Standard range electric wiring

Rep.	Designation	Rep.	Designation
FC0	Open limit switch	FC1	Auxiliary limit switch 1
FCF	Close limit switch	FC2	Auxiliary limit switch 2
D1/D2	Failure report Terminal strip (24V DC / 3A max)		



The terminal temperature can reach 90°C
The used wires must be rigid (feedback voltages : 4 to 250V AC/DC)

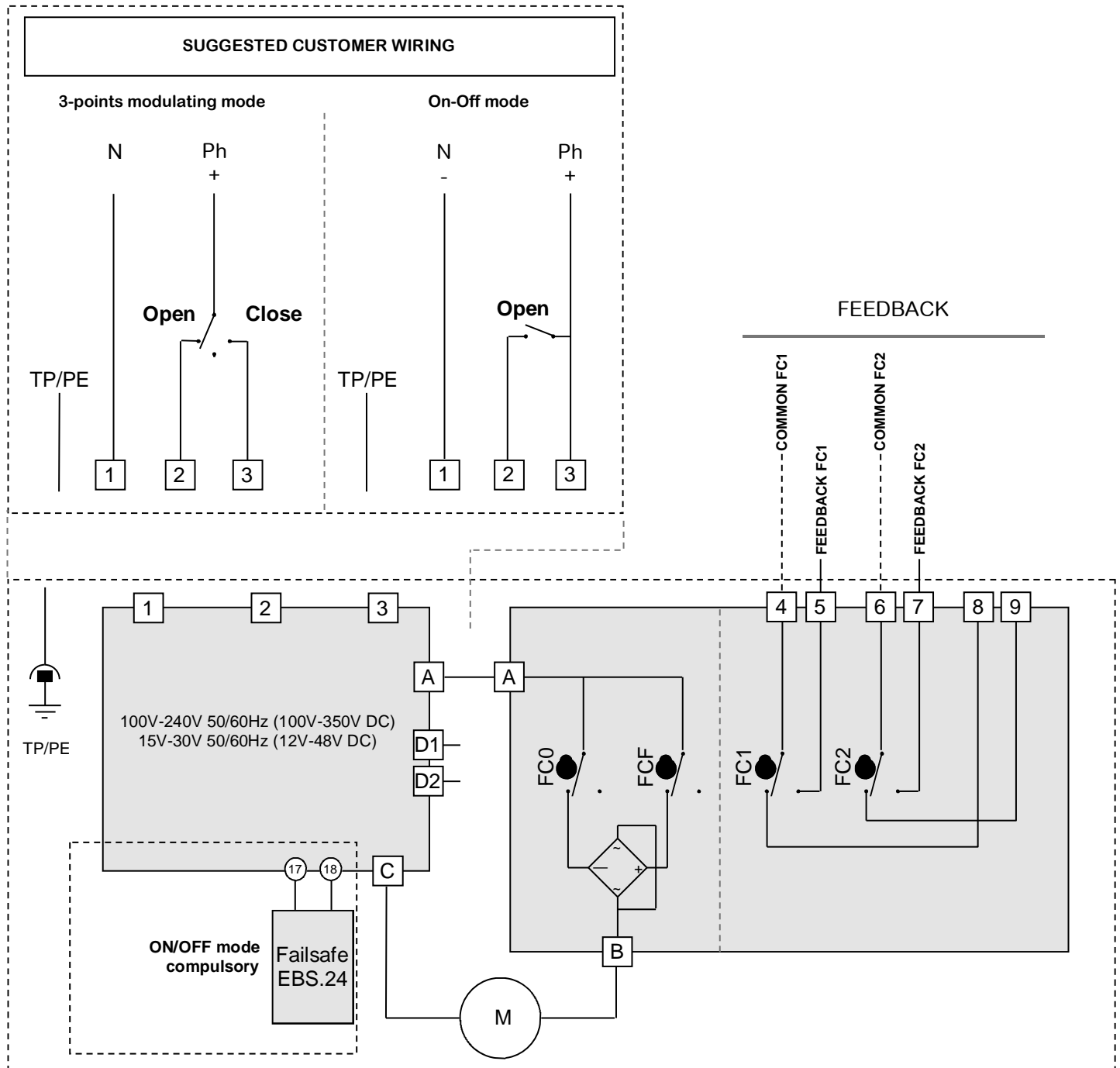

400V 3-phase VR-VS range electric wiring

Rep.	Designation	Rep.	Designation	Rep.	Designation
FC0	Open limit switch	H4	Motor supply indication	S5	Stop button
FCF	Close limit switch	H5	Control supply indication	S6	Opening button
FC1	Auxiliary limit switch 1	KM1	Opening switch	S7	Closing button
FC2	Auxiliary limit switch 2	KM2	Closing switch	H	Heating resistor
F1 / F2	Thermal switch	M	Motor		



The terminal temperature can reach 90°C
The used wires must be rigid (feedback voltages : 4 to 250V AC/DC)

ALIMENTATION (400V 3-phase 50/60Hz)

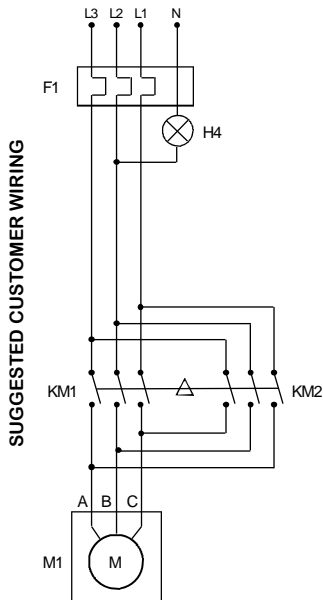

COMMAND (230V AC)

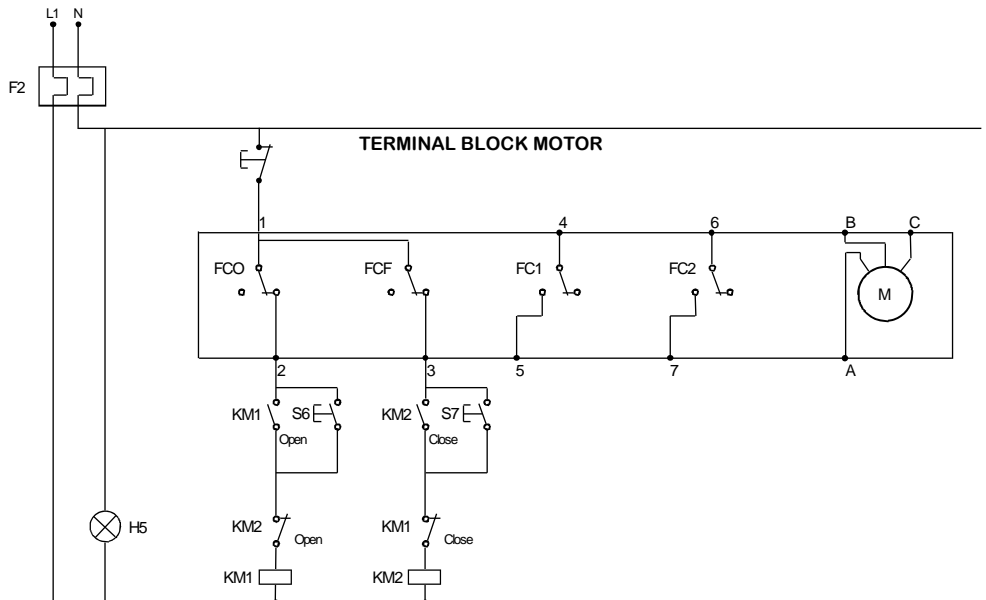

ERT.B

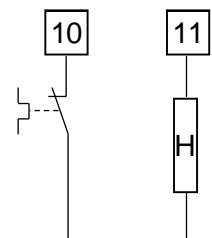

The motor power supply is wired on bistable three-phase relay (not delivered)
If working inverted, invert 2 phases of motor

Description

Electric actuators, aluminium housing, with manual override by hand wheel, for torques from 600 to 2400mN and in accordance with CE-ROHS-REACH Directives.



Technical datas VT	
Visual position indicator	Spherical
Control	3-modulating points
Voltages	230V AC (50/60Hz) • 400V 3-phase 50Hz
Duty cycle	Service S4 - 50% (IEC34 standard)
Torque limiter	Mecanical
Number of starts / hour ¹⁾	50
Feedback relay	Failure (torque)
Anti-condensation heater	Self-regulated
Drive nut	VT600-1000: star 36 • VT1500-2400: star 46
Removable adaptation plates (ISO5211)	VT600-1000: F10-F12 • VT1500-2400: F12-F14-F16
Number of limit switches	4 adjustable switches (5A max.)
Secured manual override	Wheel
Mechanical travel stops	90° ± 5° (180° et 270° versions without mechanical travel stops)
Electric connection	2 ISO M20
Temperature	-20°C to +70°C (FAILSAFE actuator: -10°C to +40°C)
Enclosure	IP68
Weight	VT600-1000 : 24Kg • VT1500-2400 : 54Kg
Warranty ²⁾	3-year warranty or 50 000 actuations

¹⁾ Recommended use, see instructions notice.

²⁾ Tested on testing bench in the worst conditions (maximal torque and duty rating).

Options

Card with two extra limit switches (EFC.2)
100 / 1000 / 5000 / 10000 Ohms feedback potentiometer (EPR.B)
0-10V, 0-20mA or 4-20mA transmitter (EPT.C) ³⁾
1 or 2 connector M12 3P+T (ECM.1 or ECM.2)

³⁾ Specify the model.



Please consider 1.5 safety factor (and 2.0 safety factor for POSI version) when sizing the actuator

VT range

Code	Star drive nut Connection	Torque	Voltage supplies	Power	Operating time
VT600.A08.G00	36 F10/F12	600Nm	230V AC 50/60Hz	250W	38s
VT1000.A08.G00	36 F10/F12	1000Nm	230V AC 50/60Hz	250W	38s
VT1500.B08.G00	46 F14	1500Nm	230V AC 50/60Hz	250W	113s
VT1500.C08.G00	46 F12/F16	1500Nm	230V AC 50/60Hz	250W	113s
VT2400.B08.G00	46 F14	2400Nm	230V AC 50/60Hz	250W	113s
VT2400.C08.G00	46 F12/F16	2400Nm	230V AC 50/60Hz	250W	113s
VT600.A09.R00	36 F10/F12	600Nm	400V TRI 50Hz	250W	38s
VT1000.A09.R00	36 F10/F12	1000Nm	400V TRI 50Hz	250W	38s
VT1500.B09.R00	46 F14	1500Nm	400V TRI 50Hz	250W	113s
VT1500.C09.R00	46 F12/F16	1500Nm	400V TRI 50Hz	250W	113s
VT2400.B09.R00	46 F14	2400Nm	400V TRI 50Hz	250W	113s
VT2400.C09.R00	46 F12/F16	2400Nm	400V TRI 50Hz	250W	113s

Dimensions

Type : VT 600 to 1000Nm



Type : VT 1500 to 2400Nm

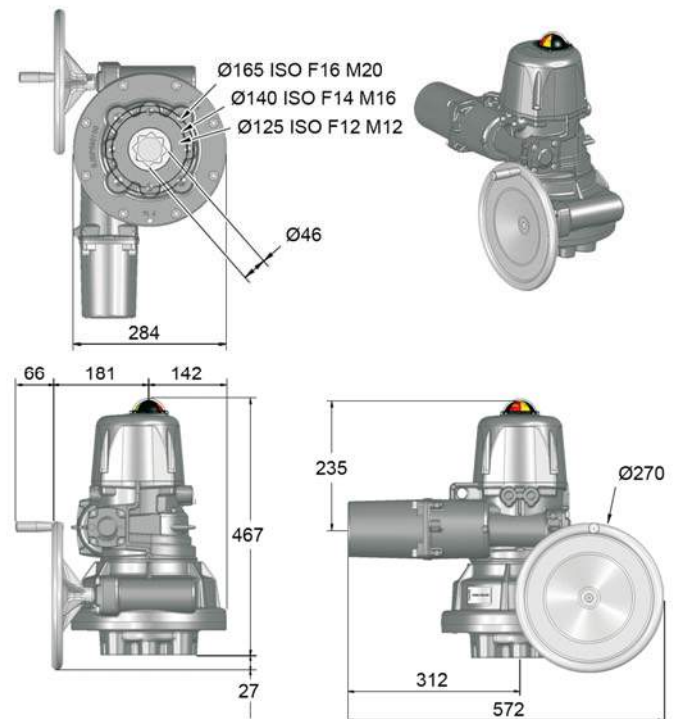

Please consider 1.5 safety factor when sizing the actuator

VT 230V electric wiring

Rep.	Designation	Rep.	Designation	Rep.	Designation
FCO	Open limit switch	FCF	Close limit switch	TLO	Torque switch : opening
FC1	Auxiliary limit switch 1	FC2	Auxiliary limit switch 2	TLF	Torque switch : closing
C	Capacitor	F	Motor thermoswitch	H	Anti-condensation heater
M	Motor	VL	Purple	MR	Brown
RG	Red	NR	Black	BU	Blue
OG	Orange	BC	White	D1/D2	Failure report Terminal strip (230V AC max / 5 A)



The terminal temperature can reach 90°C
The used wires must be rigid (feedback voltages : 4 to 250V AC/DC)

POWER SUPPLY AND COMMAND

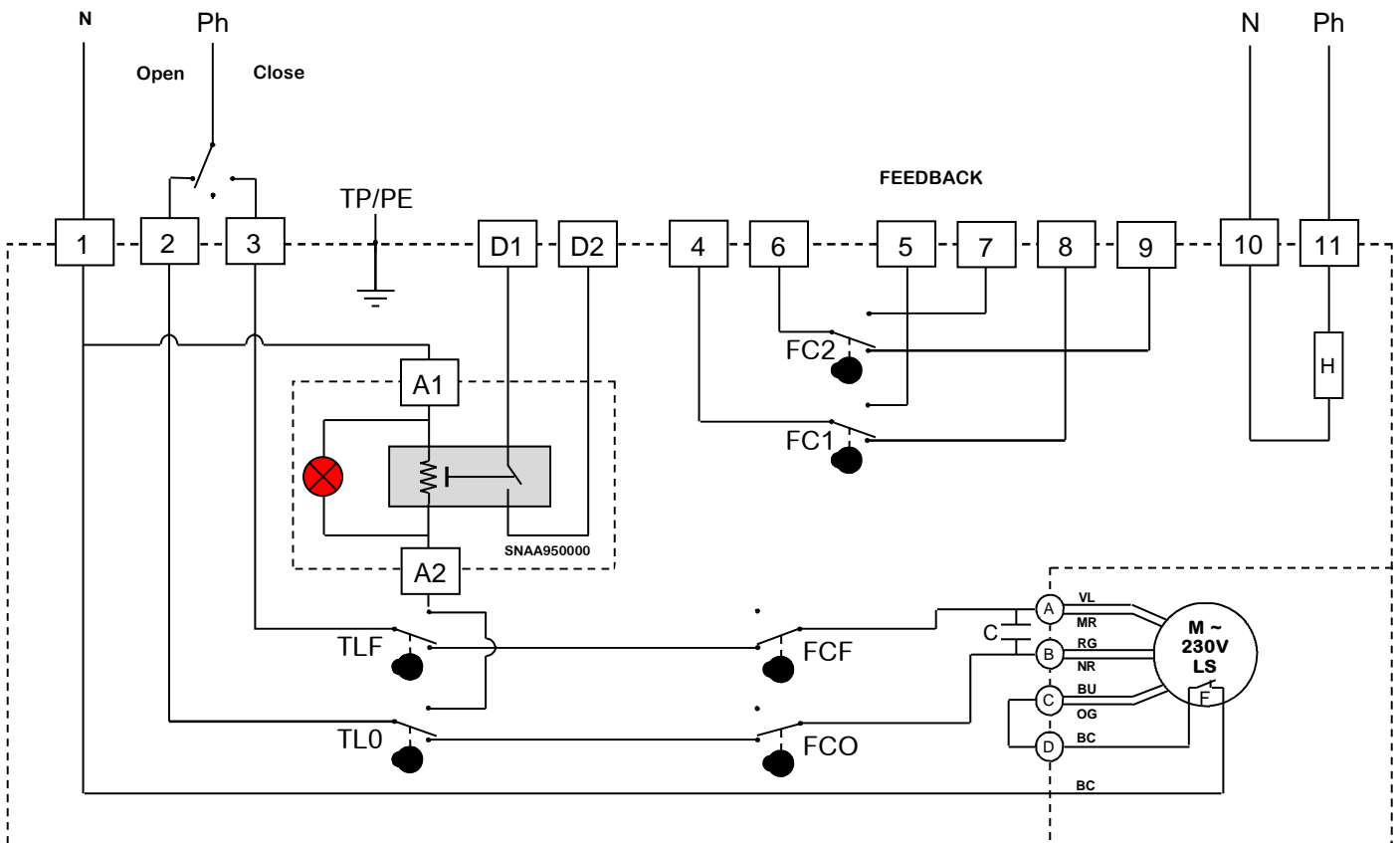

VT 400V 3-phase electric wiring

Rep.	Designation	Rep.	Designation	Rep.	Designation
FC0	Open limit switch	FCF	Close limit switch	TLO	Torque switch : opening
FC1	Auxiliary limit switch 1	FC2	Auxiliary limit switch 2	TLF	Torque switch : closing
BC	White	F	Contact thermique moteur	H	Anti-condensation heater
M	Motor	VL	Purple	MR	Brown
RG	Red	NR	Black	BU	Blue
OG	Orange	D1/D2	Failure report Terminal strip (230V AC max / 5 A)		



The terminal temperature can reach 90°C
The used wires must be rigid (feedback voltages : 4 to 250V AC/DC)

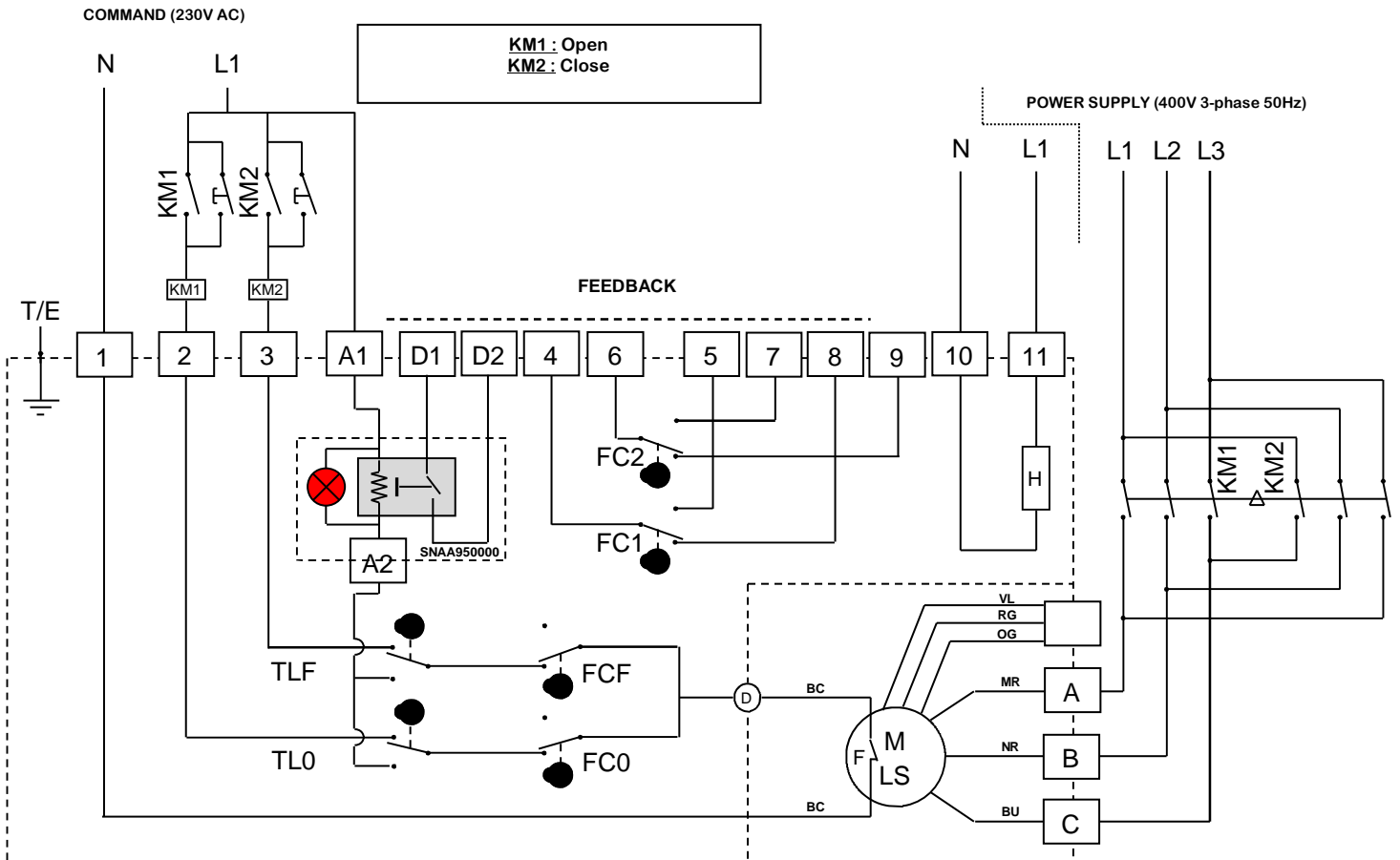

The motor power supply is wired on bistable three-phase relay (not delivered)
If working inverted, invert 2 phases of motor

VR and VS FAILSAFE actuators

Description

Failsafe actuators integrate battery pack monitored by electronic board in the actuator. Its function is to relay in case of power supply failure on terminal PIN 1, 2 and 3 of the actuator. The failsafe actuators can be set on different position like normally open (NO) or normally close (NC) depends on customer application.

The electronic board monitors the battery pack and check the status of battery (cycle load and failure). If a battery failure is detected, a contact on PIN 66 and 66 switch off. If customer use this contact he could be aware that there is a failure on battery in the actuator without remove cover and plan the replacement.

Failsafe option required ON/OFF mode.

Advantages

- All in one: no additional wiring required
- Cost effective
- Battery gauge active 24H/24H
- Power shut off after 2 mn to avoid battery discharging
- Quick and easy replacement of the battery
- 2 initial position settings: “normally open” or “normally closed”
- Battery failure feedback relai

Working principle

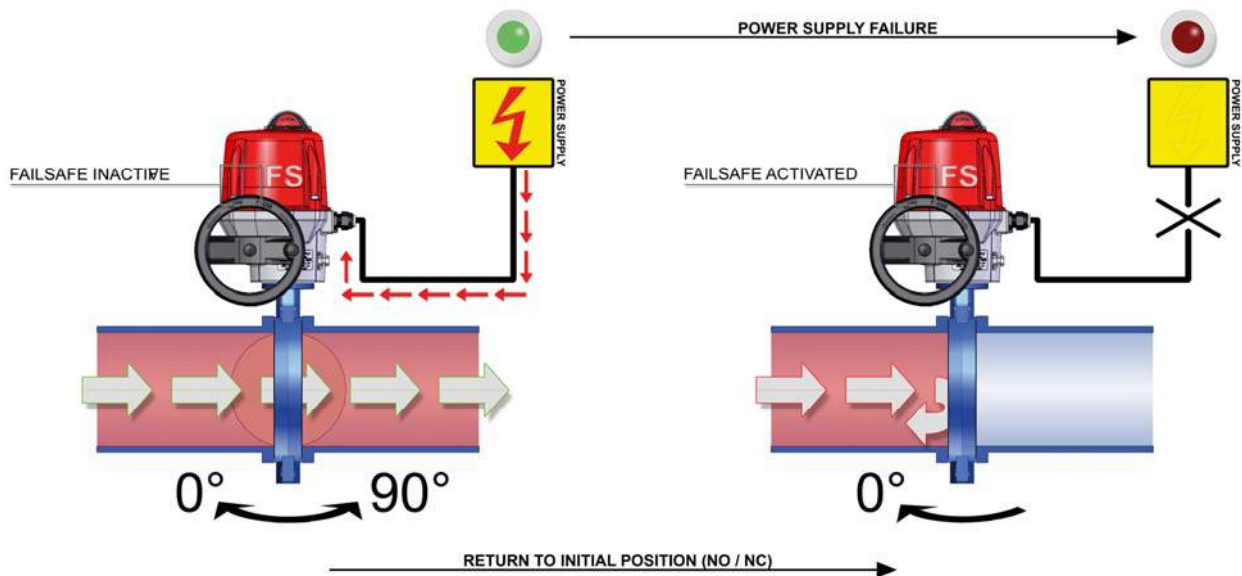

Please consider 1.5 safety factor (and 2.0 safety factor for POSI version) when sizing the actuator

VR and VS FAILSAFE range

Code	Star drive nut Connection	Torque	Voltage supplies	Power	Operating time
VR25.70A.GS2	17 F05/F07	25Nm	100V to 240V 50/60Hz (100V to 350V DC)	45W	7s
VR25.70B.GS2	17 F05/F07	25Nm	15V to 30V 50/60Hz (12V to 48V DC)	45W	7s
VR45.70A.GS2	17 F05/F07	45Nm	100V to 240V 50/60Hz (100V to 350V DC)	45W	15s
VR45.70B.GS2	17 F05/F07	45Nm	15V to 30V 50/60Hz (12V to 48V DC)	45W	15s
VR75.70A.GS2	17 F05/F07	75Nm	100V to 240V 50/60Hz (100V to 350V DC)	45W	20s
VR75.70B.GS2	17 F05/F07	75Nm	15V to 30V 50/60Hz (12V to 48V DC)	45W	20s
VS100.90A.GS2	22 F07/F10	100Nm	100V to 240V 50/60Hz (100V to 350V DC)	45W	15s
VS100.90B.GS2	22 F07/F10	100Nm	15V to 30V 50/60Hz (12V to 48V DC)	45W	15s
VS150.90A.GS2	22 F07/F10	150Nm	100V to 240V 50/60Hz (100V to 350V DC)	45W	30s
VS150.90B.GS2	22 F07/F10	150Nm	15V to 30V 50/60Hz (12V to 48V DC)	45W	30s
VS300.90A.GS2	22 F07/F10	300Nm	100V to 240V 50/60Hz (100V to 350V DC)	45W	60s
VS300.90B.GS2	22 F07/F10	300Nm	15V to 30V 50/60Hz (12V to 48V DC)	45W	60s



Please consider 1.5 safety factor (and 2.0 safety factor for POSI version) when sizing the actuator

VR and VS FAILSAFE actuators electric wiring

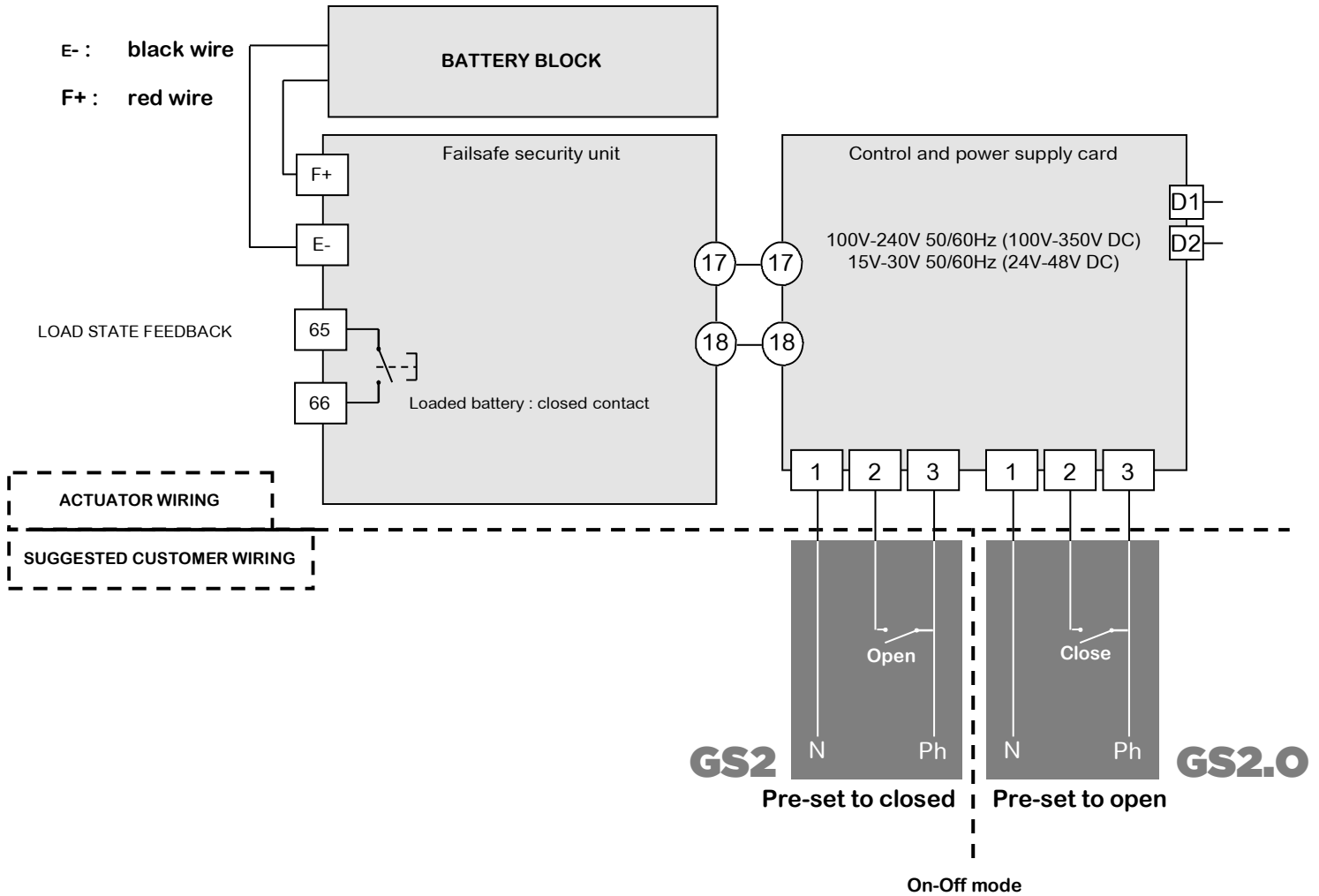

The terminal temperature can reach 90°C
The two functioning modes « pre-set to closed » and « pre-set to open » are two different products (pre-set in factory) and can't be interchangeable.

VR and VS POSI actuators

Description

Actuator V series with advanced and friendly positioning solution, allowing the control of a valve with a signal: 0-10V, 4-20mA or 0-20mA. For applications like dosing, modulating, flow control, filling up (increases the accuracy in the last stage), mixing...

Advantages

- All in one: no additional wiring required
- Cost effective
- Microprocessor base
- Secured process (memorization loops)
- Self configurable (0-20mA/4-20mA/0-10V)
- Reversible (exemple : 20-4mA)
- Training mode
- Anti condensation heater
- Electronic torque limiter
- Failure feedback relay
- Rotation up to 180° or 270° (on request)
- Preset from factory

Working principle

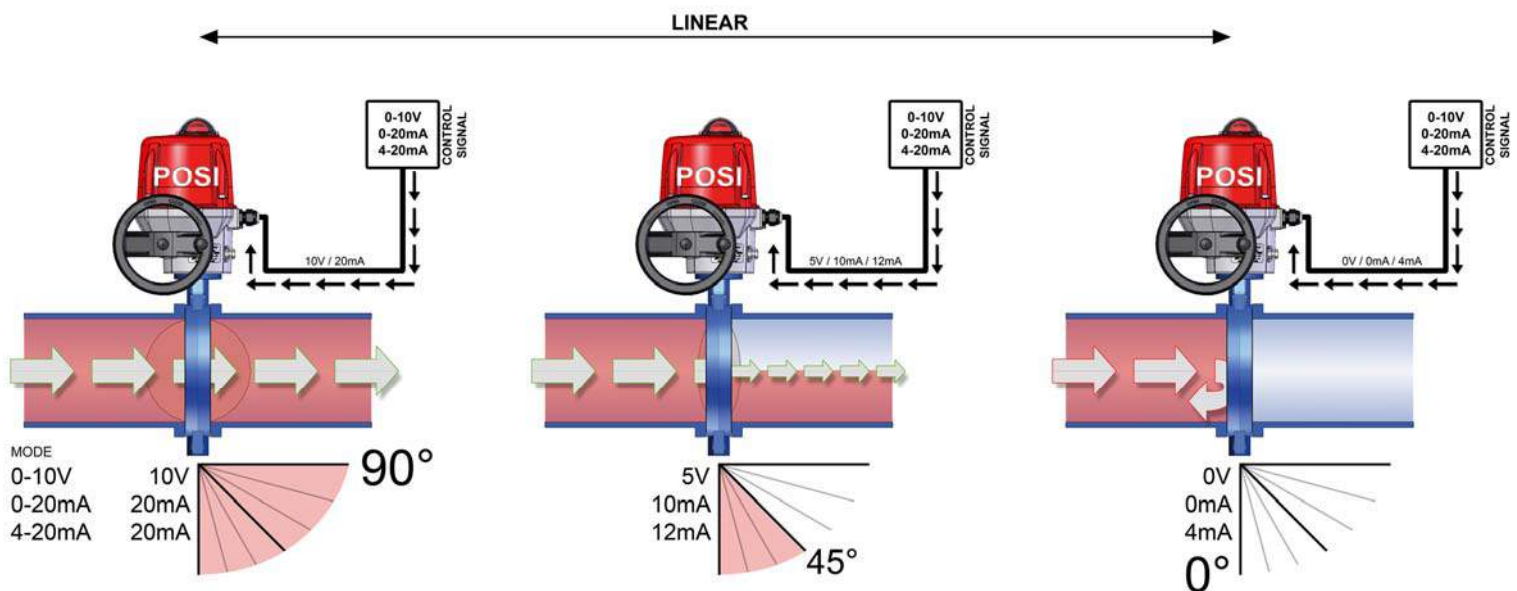

Please consider 1.5 safety factor (and 2.0 safety factor for POSI version) when sizing the actuator

VR and VS POSI actuators

Various control types (control signal on terminals N°15 and N°16)

On request, our cards can be set in factory. The consign and the feedback signal can have different forms (current or voltage). Without any information from the customer, the cards are set for current 4-20mA (control + feedback signal).

Control in 0-10V modes:

In case of outside event, absence of control signal (accidental wires cut for example) but in presence of power, the actuator will travel to defined position (open or closed valve).

In standard our actuators will close themselves in absence of control signal but there are other possibilities on request.

Control in 4-20mA mode:

In case of outside event, absence of control signal (accidental wires cut for example) but in presence of power, the actuator will stay in its position.

In the both cases, when the control signal is restored, the actuator reach automatically the position corresponding to control signal value.

VR and VS POSI range

Code	Star drive nut Connection	Torque	Voltage supplies	Power	Operating time
VR25.70A.GP5	17 F05/F07	25Nm	100V to 240V 50/60Hz (100V to 350V DC)	45W	15s
VR25.70B.GP5	17 F05/F07	25Nm	15V to 30V 50/60Hz (12V to 48V DC)	45W	15s
VR45.70A.GP5	17 F05/F07	45Nm	100V to 240V 50/60Hz (100V to 350V DC)	45W	15s
VR45.70B.GP5	17 F05/F07	45Nm	15V to 30V 50/60Hz (12V to 48V DC)	45W	15s
VR75.70A.GP5	17 F05/F07	75Nm	100V to 240V 50/60Hz (100V to 350V DC)	45W	20s
VR75.70B.GP5	17 F05/F07	75Nm	15V to 30V 50/60Hz (12V to 48V DC)	45W	20s
VS100.90A.GP5	22 F07/F10	100Nm	100V to 240V 50/60Hz (100V to 350V DC)	45W	15s
VS100.90B.GP5	22 F07/F10	100Nm	15V to 30V 50/60Hz (12V to 48V DC)	45W	15s
VS150.90A.GP5	22 F07/F10	150Nm	100V to 240V 50/60Hz (100V to 350V DC)	45W	30s
VS150.90B.GP5	22 F07/F10	150Nm	15V to 30V 50/60Hz (12V to 48V DC)	45W	30s
VS300.90A.GP5	22 F07/F10	300Nm	100V to 240V 50/60Hz (100V to 350V DC)	45W	60s
VS300.90B.GP5	22 F07/F10	300Nm	15V to 30V 50/60Hz (12V to 48V DC)	45W	60s



Please consider 1.5 safety factor (and 2.0 safety factor for POSI version) when sizing the actuator

VR and VS POSI actuators electric wiring

Rep.	Designation	Rep.	Designation
FC0	Open limit switch	FC1	Auxiliary limit switch 1
FCF	Close limit switch	FC2	Auxiliary limit switch 2
D1/D2	Failure report Terminal strip (24V DC / 3A max)		

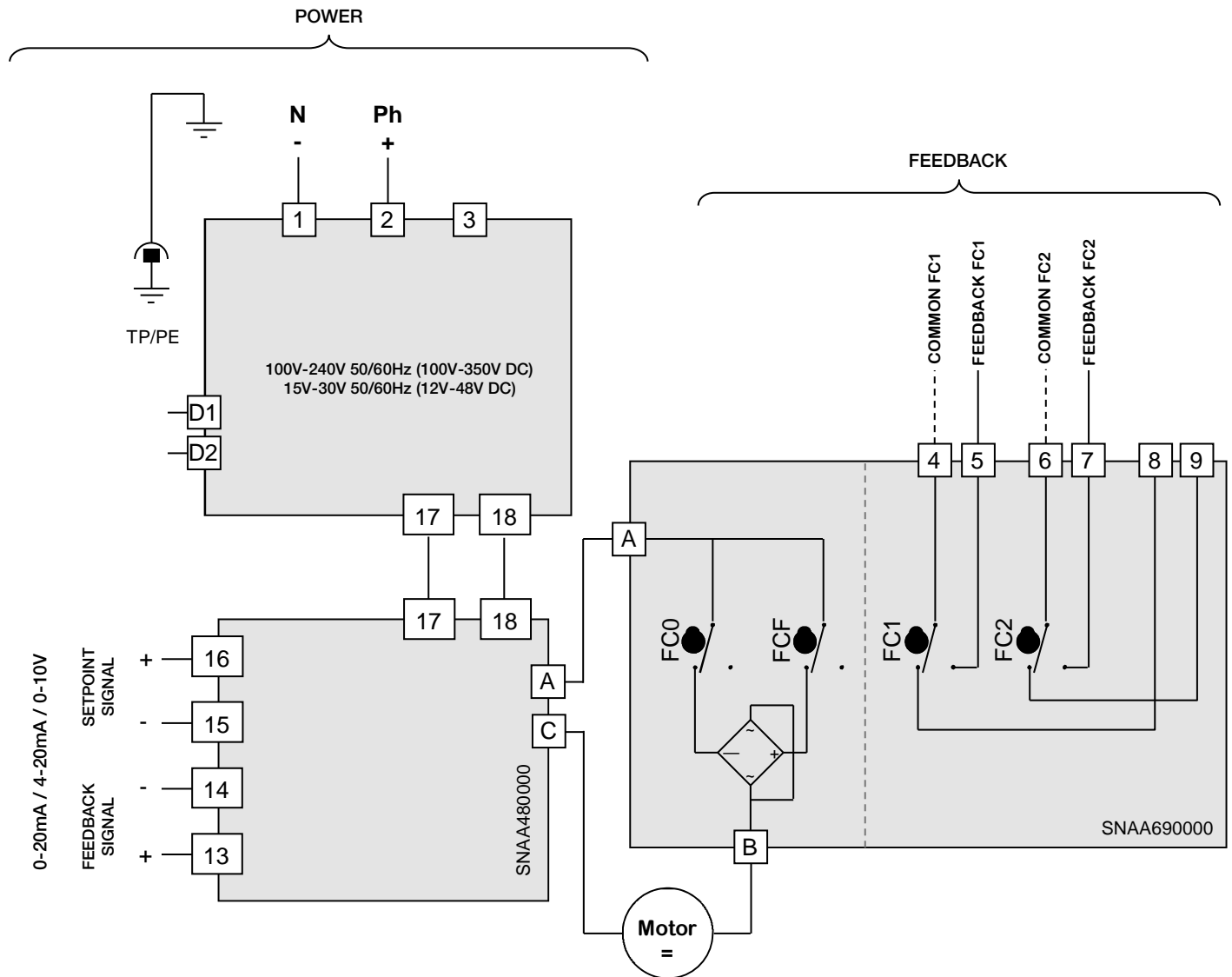

- The card resolution is 1°
- 10 KOhm input impedance if control with voltage (0-10V) / 100 Ohm input impedance if control with current (0-20mA ou 4-20mA)



- The terminal temperature can reach 90°C
- The used wires must be rigid (feedback voltages : 4 to 250V AC/DC)
- For a use with a long wiring, the induction current generated by the wires mustn't be higher than 1mA
- La tension de pilotage doit être de type T.B.T.S. (Très Basse Tension de Sécurité)
- No common earth/ground connexion between the control (input and output signal) and the alimentation. (Type 0-20 or 4-20mA : 5V DC max.)

VR and VS 3-position actuators

Description

Actuator V series with 3rd position card, allowing an intermediate position of the actuator between 0° and 90° (or 0° and 180°, or 0° and 270°). Can be used to stop the actuator at 90° in case of a 180° 3-way valve. Or for any other application which requires a partial opening before full closing

Advantages

- All in one: no additional wiring required
- Cost effective
- Quick and easy setup
- 7 limit switches
- Anti condensation heater
- Electronic torque limiter
- Failure report
- Rotation up to 180° (or 270° on request)
- Preset from factory

Working principle

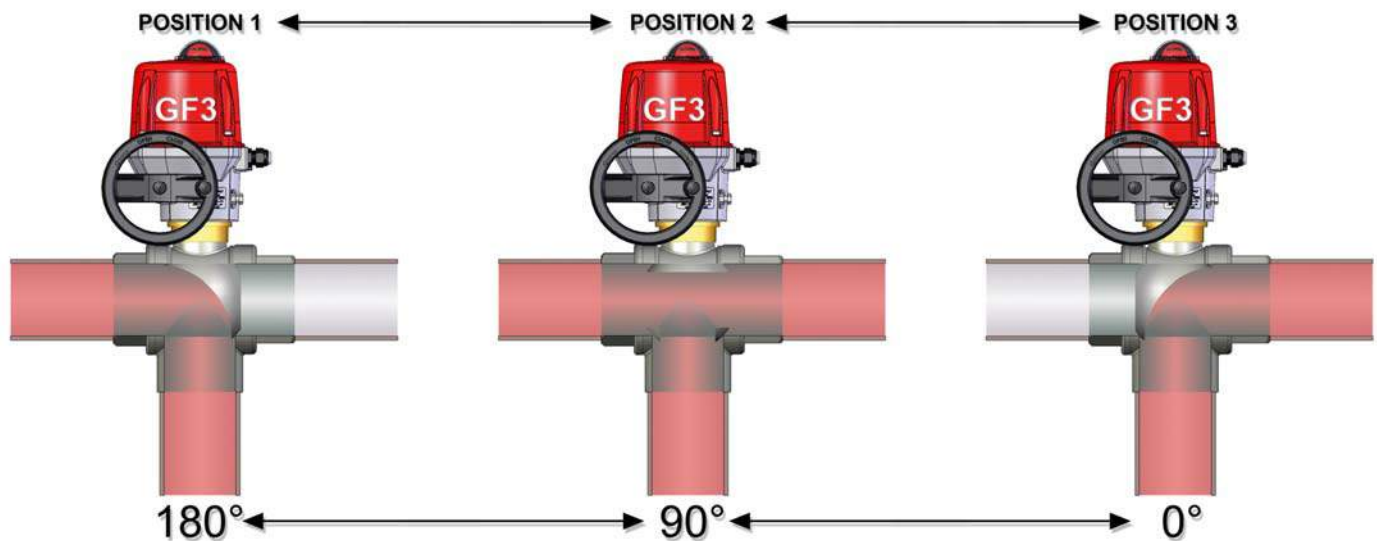

Please consider 1.5 safety factor (and 2.0 safety factor for POSI version) when sizing the actuator

VR and VS 3-position actuators

GF3 option allow actuator to be drive and stop in 3 positions.

These 3 positions could be between 0° to 180°. In standard actuators are setting in our workshop at 0° 90° 180° that's fit with standard 3 ways ball valve . Others positions still available but customer have to price on the order which position is requested. These 3 positions are driven by 4 switches (FCO,FCF,FCIO and FCIF) and 3 switches for feed back signal Switches FC1,FC2 are NO contact (close the circuit in extreme position) and FC3 is a NC contact (open the circuit in intermediate position).

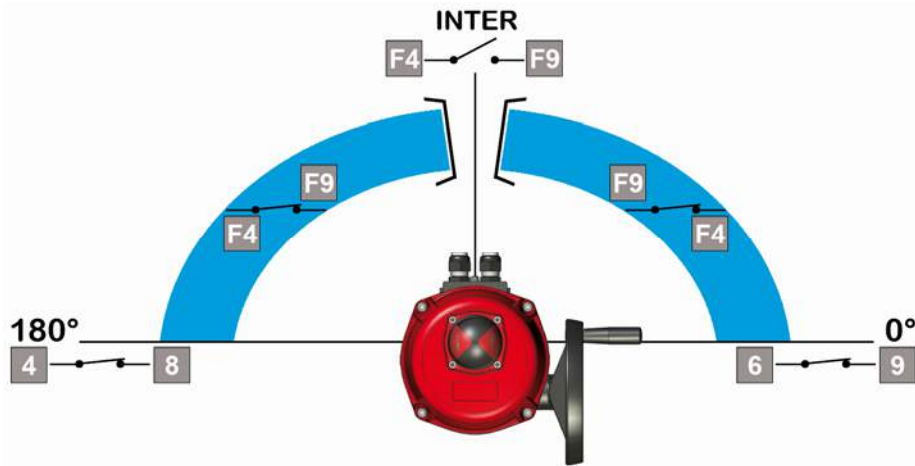

Code	Star drive nut Connection	Torque	Voltage supplies	Power	Operating time
VR25.70A.GF3	17 F05/F07	25Nm	100V to 240V 50/60Hz (100V to 350V DC)	45W	7s
VR25.70B.GF3	17 F05/F07	25Nm	15V to 30V 50/60Hz (12V to 48V DC)	45W	7s
VR45.70A.GF3	17 F05/F07	45Nm	100V to 240V 50/60Hz (100V to 350V DC)	45W	15s
VR45.70B.GF3	17 F05/F07	45Nm	15V to 30V 50/60Hz (12V to 48V DC)	45W	15s
VR75.70A.GF3	17 F05/F07	75Nm	100V to 240V 50/60Hz (100V to 350V DC)	45W	20s
VR75.70B.GF3	17 F05/F07	75Nm	15V to 30V 50/60Hz (12V to 48V DC)	45W	20s
VS100.90A.GF3	22 F07/F10	100Nm	100V to 240V 50/60Hz (100V to 350V DC)	45W	15s
VS100.90B.GF3	22 F07/F10	100Nm	15V to 30V 50/60Hz (12V to 48V DC)	45W	15s
VS150.90A.GF3	22 F07/F10	150Nm	100V to 240V 50/60Hz (100V to 350V DC)	45W	30s
VS150.90B.GF3	22 F07/F10	150Nm	15V to 30V 50/60Hz (12V to 48V DC)	45W	30s
VS300.90A.GF3	22 F07/F10	300Nm	100V to 240V 50/60Hz (100V to 350V DC)	45W	60s
VS300.90B.GF3	22 F07/F10	300Nm	15V to 30V 50/60Hz (12V to 48V DC)	45W	60s



Please consider 1.5 safety factor (and 2.0 safety factor for POSI version) when sizing the actuator

VR and VS 3-position actuators electric wiring

Rep.	Designation	Rep.	Designation
FC0	Open limit switch	FC1	Auxiliary limit switch 1
FCF	Close limit switch	FC2	Auxiliary limit switch 2
FCIO	Intermediate open limit switch	FC3	Auxiliary limit switch 3
FCIF	Intermediate close limit switch	R	Red
W	White	B	Black
D1/D2	Failure report Terminal strip (24V DC / 3A max)		



The terminal temperature can reach 90°C
The used wires must be rigid (feedback voltages : 4 to 250V AC/DC)

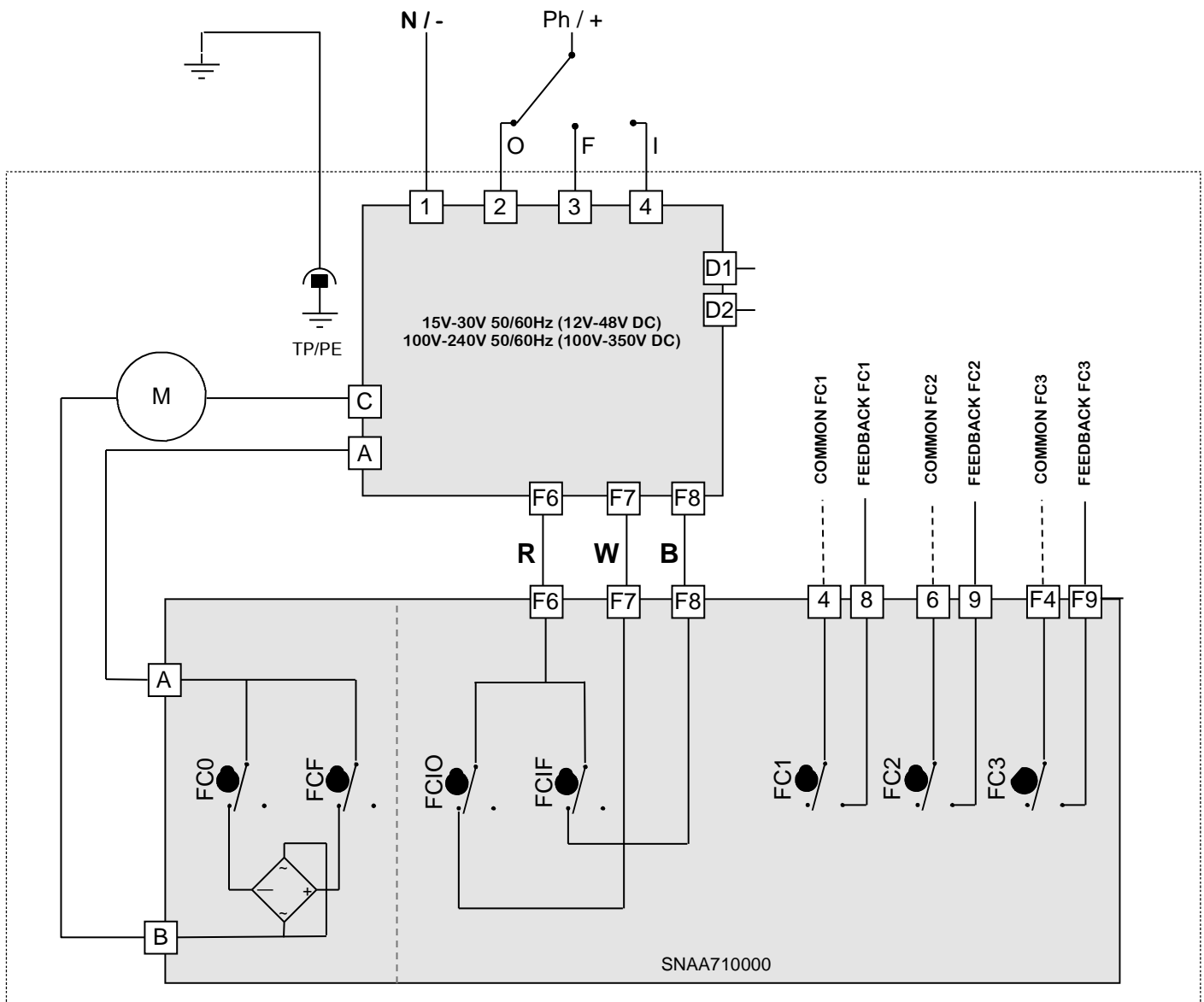

VR and VS POSI-SAFE actuators

Description

The VR and VS (polyamide cover only) GPS models incorporate a FAILSAFE security module and a positioning electronic card (GS2 model coupled with GP5 model).

Advantages

- All in one: no additional wiring
- Compact, reduced overall dimensions
- One unique IP68 for 2 functions
- No additional wiring
- User friendly connecting and servicing
- Cost effective
- Battery gauge
- Power shut off after 2mn to avoid battery discharging
- Quick and easy replacement of the battery
- 2 initial position settings: "normally open" or "normally closed"
- Microprocessor base
- Secured process (memorization loops)
- Self configurable (4-20mA/0-10V)
- Reversible (example: 20-4mA)
- Feedback signal 4-20mA or 0-10V
- Training mode
- Anti condensation heater
- Electronic torque limiter
- Failure feedback relay
- Rotation up to 180° or 270° (on request)
- Preset in factory

Code	Star drive nut Connection	Torque	Voltage supplies	Power	Operating time
VR25.70A.GPS	17 F05/F07	25Nm	100V to 240V 50/60Hz (100V to 350V DC)	45W	15s
VR25.70B.GPS	17 F05/F07	25Nm	15V to 30V 50/60Hz (12V to 48V DC)	45W	15s
VR45.70A.GPS	17 F05/F07	45Nm	100V to 240V 50/60Hz (100V to 350V DC)	45W	15s
VR45.70B.GPS	17 F05/F07	45Nm	15V to 30V 50/60Hz (12V to 48V DC)	45W	15s
VR75.70A.GPS	17 F05/F07	75Nm	100V to 240V 50/60Hz (100V to 350V DC)	45W	20s
VR75.70B.GPS	17 F05/F07	75Nm	15V to 30V 50/60Hz (12V to 48V DC)	45W	20s
VS100.90A.GPS	22 F07/F10	100Nm	100V to 240V 50/60Hz (100V to 350V DC)	45W	15s
VS100.90B.GPS	22 F07/F10	100Nm	15V to 30V 50/60Hz (12V to 48V DC)	45W	15s
VS150.90A.GPS	22 F07/F10	150Nm	100V to 240V 50/60Hz (100V to 350V DC)	45W	30s
VS150.90B.GPS	22 F07/F10	150Nm	15V to 30V 50/60Hz (12V to 48V DC)	45W	30s
VS300.90A.GPS	22 F07/F10	300Nm	100V to 240V 50/60Hz (100V to 350V DC)	45W	60s
VS300.90B.GPS	22 F07/F10	300Nm	15V to 30V 50/60Hz (12V to 48V DC)	45W	60s



Please consider 1.5 safety factor (and 2.0 safety factor for POSI version) when sizing the actuator

VR and VS POSI-SAFE actuators electric wiring

Rep.	Designation	Rep.	Designation
FC0	Open limit switch	FC1	Auxiliary limit switch 1
FCF	Close limit switch	FC2	Auxiliary limit switch 2
D1/D2	Failure report Terminal strip (24V DC / 3A max)		

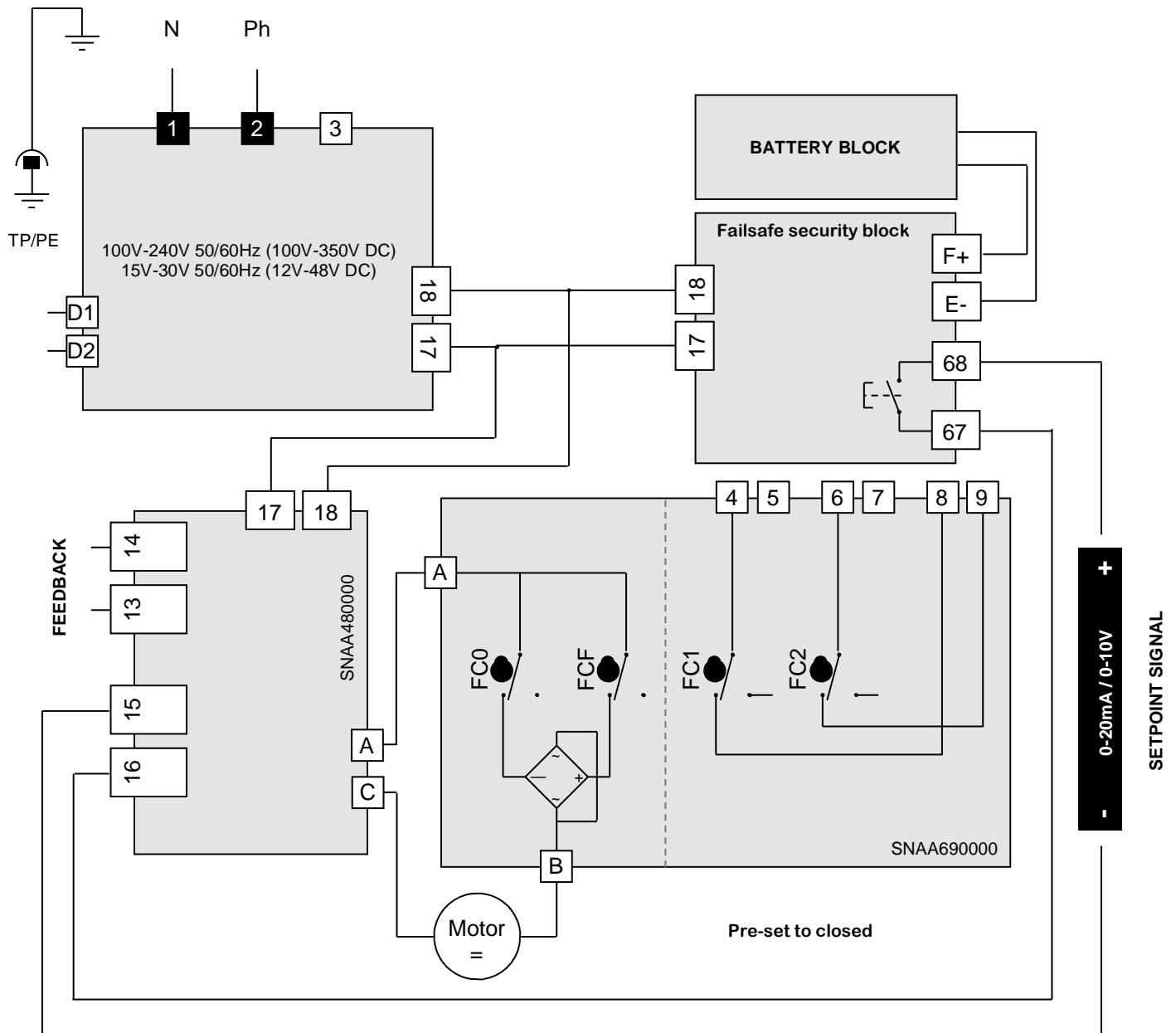

- The card resolution is 1°
- 10 KOhm input impedance if control with voltage (0-10V) / 100 Ohm input impedance if control with current (0-20mA ou 4-20mA)



- The terminal temperature can reach 90°C
- The used wires must be rigid (feedback voltages : 4 to 250V AC/DC)
- For a use with a long wiring, the induction current generated by the wires mustn't be higher than 1mA
- La tension de pilotage doit être de type T.B.T.S. (Très Basse Tension de Sécurité)
- No common earth/ground connexion between the control (input and output signal) and the alimentation. (Type 0-20 or 4-20mA : 5V DC max.)
- The terminal switch 67 68 must be wired with positive DC current (24V 3A max.).

VR and VS 3-POSITION-SAFE actuators

Description

The VR and VS GFS models incorporate a FAILSAFE security module and a 3-position system (GS2 model coupled with GF3 model).

Avantages

- All in one: no additional wiring
- Compact, reduced overall dimensions
- One unique IP68 for 2 functions
- No additional wiring
- Easy connecting and servicing
- Cost effective
- Battery gauge
- Power shut off after 2mn to avoid battery discharging
- Quick and easy replacement of the battery
- Quick and easy setup
- 7 limit switches
- Anti condensation heater
- Electronic torque limiter
- Failure report
- Rotation up to 180° (or 270° on request)
- Preset in factory

Code	Star drive nut Connection	Torque	Voltage supplies	Power	Operating time
VR25.70A.GFS	17 F05/F07	25Nm	100V to 240V 50/60Hz (100V to 350V DC)	45W	7s
VR25.70B.GFS	17 F05/F07	25Nm	15V to 30V 50/60Hz (12V to 48V DC)	45W	7s
VR45.70A.GFS	17 F05/F07	45Nm	100V to 240V 50/60Hz (100V to 350V DC)	45W	15s
VR45.70B.GFS	17 F05/F07	45Nm	15V to 30V 50/60Hz (12V to 48V DC)	45W	15s
VR75.70A.GFS	17 F05/F07	75Nm	100V to 240V 50/60Hz (100V to 350V DC)	45W	20s
VR75.70B.GFS	17 F05/F07	75Nm	15V to 30V 50/60Hz (12V to 48V DC)	45W	20s
VS100.90A.GFS	22 F07/F10	100Nm	100V to 240V 50/60Hz (100V to 350V DC)	45W	15s
VS100.90B.GFS	22 F07/F10	100Nm	15V to 30V 50/60Hz (12V to 48V DC)	45W	15s
VS150.90A.GFS	22 F07/F10	150Nm	100V to 240V 50/60Hz (100V to 350V DC)	45W	30s
VS150.90B.GFS	22 F07/F10	150Nm	15V to 30V 50/60Hz (12V to 48V DC)	45W	30s
VS300.90A.GFS	22 F07/F10	300Nm	100V to 240V 50/60Hz (100V to 350V DC)	45W	60s
VS300.90B.GFS	22 F07/F10	300Nm	15V to 30V 50/60Hz (12V to 48V DC)	45W	60s



Please consider 1.5 safety factor (and 2.0 safety factor for POSI version) when sizing the actuator

VR and VS 3-POSITION-SAFE actuators electric wiring

Rep.	Designation	Rep.	Designation	Rep.	Designation
FC0	Open limit switch	FC1	Auxiliary limit switch 1	R	Red
FCF	Close limit switch	FC2	Auxiliary limit switch 2	B	Black
FCIO	Intermediate open limit switch	FC3	Auxiliary limit switch 3	W	White
FCIF	Intermediate close limit switch	D1/D2	Failure report Terminal strip (24V DC / 3A max)		

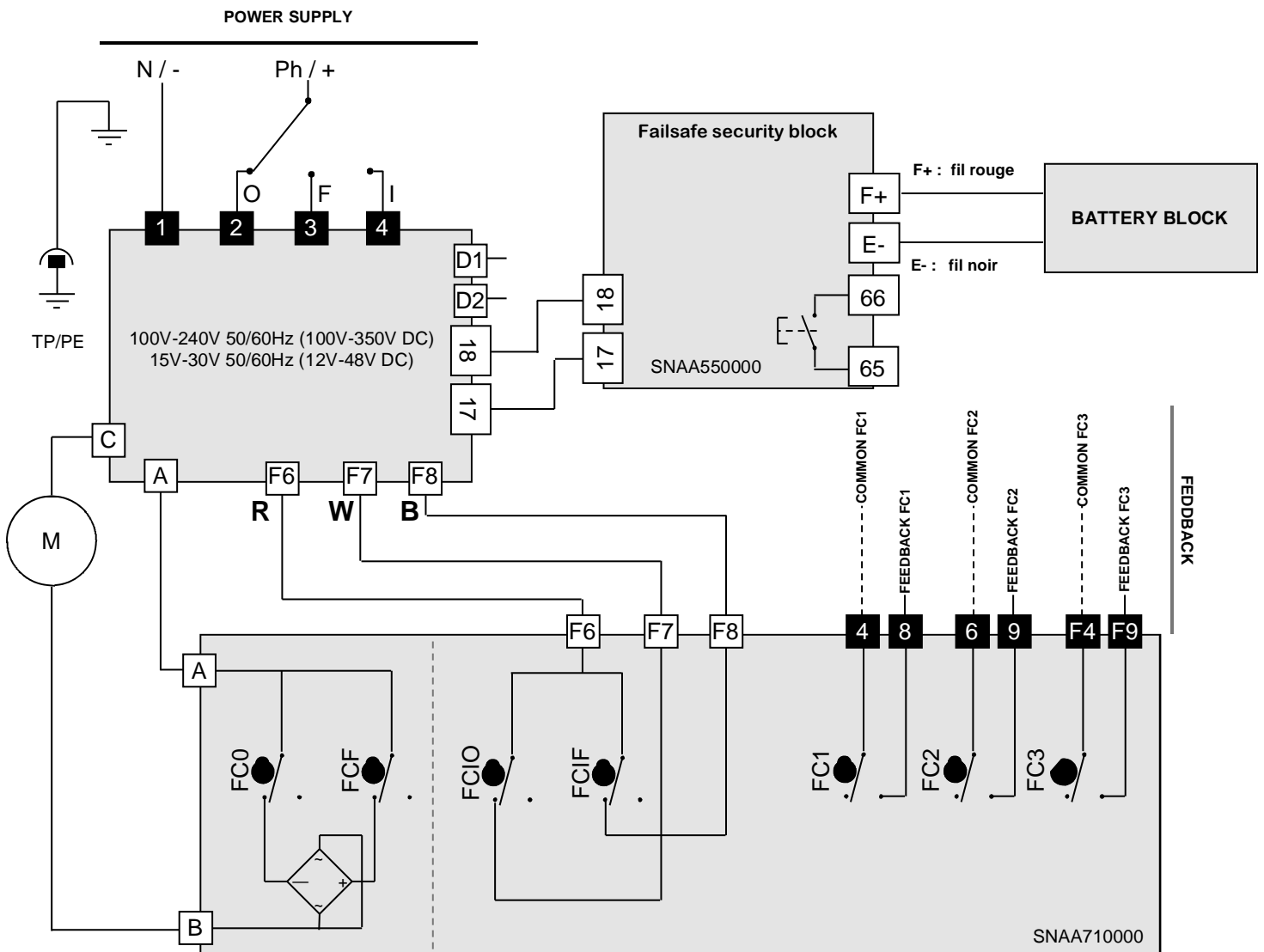

- The terminal temperature can reach 90°C
- The used wires must be rigid (feedback voltages : 4 to 250V AC/DC)
- For a use with a long wiring, the induction current generated by the wires mustn't be higher than 1mA
- La tension de pilotage doit être de type T.B.T.S. (Très Basse Tension de Sécurité)

Pour tout complément d'information, veuillez vous référer à nos documentations techniques.

Valpes se réserve à tout moment le droit de modifier ou de retirer de son offre, sans préavis ni obligation, des produits et prestations. Valpes décline toute responsabilité liée aux conséquences de l'utilisation du présent document. Exhaustivité, exactitude et actualité ne peuvent être garanties.

Valpes reserves the right to change or remove products or services from its range at any time and without prior notification or obligation. Valpes does not assume any liability for consequences resulting from the use of this

document. There is no guarantee that the information provided here is complete, accurate or up to date.
