

## FEATURES

- Reliable control in low pressure, high flow systems
- Valves do not require a minimum operating pressure
- The solenoid valves are constructed packless with a one-piece deepdrawn stainless steel core tube, ensuring safe operation of electrical and wetted moving parts
- The valves have forged brass bodies, compact design, to minimize heat radiation loss
- Hung diaphragm construction
- The solenoid valves satisfy all relevant EU Directives

## GENERAL

**Differential pressure** See «SPECIFICATIONS» [1 bar = 100 kPa]  
**Response time** 15 - 60 ms

fluids (*)	temperature range (TS)	seal materials (*)
hot water, steam	- 20°C to + 130/150°C	EPDM (ethylene-propylene)

## MATERIALS IN CONTACT WITH FLUID

(\*) Ensure that the compatibility of the fluids in contact with the materials is verified

<b>Body</b>	Brass
<b>Core tube</b>	Stainless steel
<b>Core and plugnut</b>	Stainless steel
<b>Springs</b>	Stainless steel
<b>Seat</b>	Brass
<b>Seal, diaphragm &amp; disc</b>	EPDM
<b>Shading coil</b>	Copper

## ELECTRICAL CHARACTERISTICS

**Coil insulation class** F  
**Connector** Spade plug (cable Ø 6-10 mm)  
**Connector specification** ISO 4400 / EN 175301-803, form A  
**Electrical safety** IEC 335  
**Electrical enclosure protection** Moulded IP65 (EN 60529)  
**Standard voltages** DC (=) : 24V - 48V  
(Other voltages and 60 Hz on request) AC (~) : 24V - 48V - 115V - 230V / 50 Hz

prefix option	power ratings				operator ambient temperature range (TS) (C°)	replacement coil		type <sup>(1)</sup>
	inrush ~	holding ~		hot/cold =		~	=	
	(VA)	(VA)	(W)	(W)		230 V/50 Hz	24 V DC	
SC	55	23	10,5	-	-20 to + 40	400425-117	-	01
	110	33,6	15,4	12/16,8	-20 to + 40	400525-117	400625-142	02

<sup>(1)</sup> Refer to the dimensional drawings on the following page.

## SPECIFICATIONS

pipe size	orifice size	flow coefficient Kv		min.	operating pressure differential (bar)				max. fluid temp. (°C)		power coil (W)		catalogue number
					max. (PS)								
					steam (*)		water (*) <sup>(2)</sup>						
Rp	(mm)	(m³/h)	(l/min)		~	=	~	=	~	=	~	=	
<b>NC - Normally closed</b>													
3/8	16	2,6	43,3	0	3,5	3,5	-	-	150	150	10,5	16,8	SCE222B093
1/2	16	3,5	58,3	0	3,5	3,5	-	-	150	150	10,5	16,8	SCE222B094
3/4	19	4,3	71,1	0	3,5	3,5	-	-	150	150	10,5	16,8	SCE222B095
1	25	11,1	185	0	2	-	9	-	130	130	15,4	-	SCE222B154
1 1/4	28	12,8	213,3	0	2	-	9	-	130	130	15,4	-	SCE222B155
1 1/2	32	19,3	321,6	0	2	-	9	-	130	130	15,4	-	SCE222B156

<sup>(2)</sup> Water temperature should not exceed 100°C.

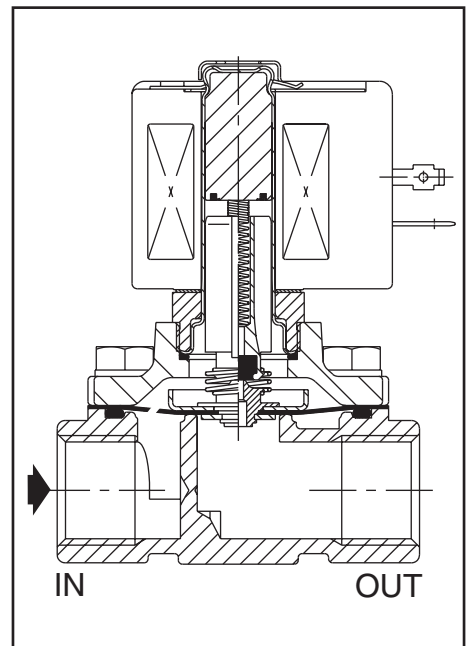

### OPTIONS

- Waterproof enclosure with embedded screw terminal coil according to protection class IP67, CEE-10
- Electrical enclosures according to "NEMA" standards are available
- Compliance with "UL", "CSA" and other local approvals available on request
- Mounting brackets (3/8, 1/2 and 3/4 only), suffix MB
- Other pipe connections are available on request
- Plug with visual indication and peak voltage suppression or with cable length of 2 m (see Solenoids, Coils & Accessories section)

### INSTALLATION

- The solenoid valves can be mounted in any position without affecting operation
- Pipe connection identifier is E = Rp (ISO 7/1)
- Installation/maintenance instructions are included with each valve

### SPARE PARTS KIT & ACCESSORIES

catalogue number	spare parts kit no.		mounting bracket no.
	~	=	
SCE222B093/094	<b>C304031</b>	<b>C132654</b>	<b>038713-000</b>
SCE222B095	<b>C123858</b>	<b>C132655</b>	<b>038713-000</b>
SCE222B154/155	<b>C133839</b>	-	-
SCE222B156	<b>C133840</b>	-	-

- Not available.

### ORDERING EXAMPLES:

<b>SC</b>	<b>E</b>	<b>222</b>	<b>B</b>	<b>093</b>	230V / 50 Hz
<b>SC</b>	<b>E</b>	<b>222</b>	<b>B</b>	<b>154</b>	115V / 50 Hz
<b>SC</b>	<b>E</b>	<b>222</b>	<b>B</b>	<b>094</b>	24V / DC
<b>SC</b>	<b>E</b>	<b>222</b>	<b>B</b>	<b>155</b>	230V / 50 Hz

prefix — pipe thread — basic number — voltage — suffix

### ORDERING EXAMPLES KITS:

	C304031	
	C132654	

basic number — suffix

### DIMENSIONS (mm), WEIGHT (kg)



#### TYPE 01-02

Prefix "SC" Solenoid  
Epoxy moulded  
IEC 335 / ISO 4400  
IP65

Type 01 (AC): SCE222B093/094/095

Type 02 (DC): SCE222B093/094/095

(AC): SCE222B154/155/156

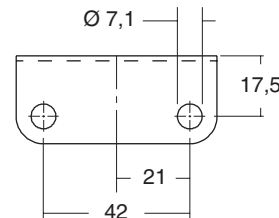
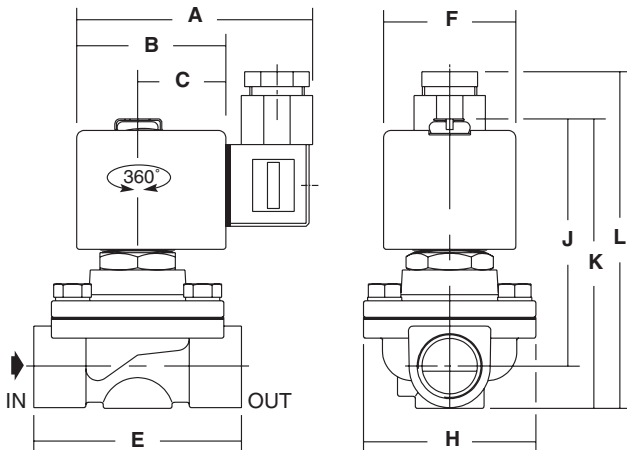

Mounting brackets  
for valves:  
SCE222B093  
SCE222B094  
SCE222B095

type	prefix option	catalogue number	A	B	C	E	F	H	J	K	L	weight <sup>(1)</sup>
01	SC	SCE222B093/094	80	50	30	70	45	58	84	96	113	1,2
		SCE222B095	80	50	30	71	45	58	87	104	121	1,3
02	SC	SCE222B093/094	86	56	33	70	50	58	91	103	105	1,4
		SCE222B095	86	56	33	71	50	58	94	111	113	1,5
		SCE222B154	86	56	33	95	50	83	110,5	131	132	2,0
		SCE222B155	86	56	33	95	50	83	117	141,5	142,5	2,0
		SCE222B156	86	56	33	111	50	99	122,5	151	152	2,6

<sup>(1)</sup> including coil and connector.

All leaflets are available on: [www.asco.com](http://www.asco.com)