



SUBSIDIARIES

BELGIUM
BERNARD CONTROLS BENELUX
 BRUXELLES

info.belux@bernardcontrols.com
 Tel +32 (0)2 343 41 22

CHINA
BERNARD CONTROLS CHINA
 PEKIN

bcc.info@bernardcontrols.com
 Tel +86 (0) 10 6789 2861

GERMANY
BERNARD CONTROLS DEUFRA
 TROISDORF

bcd.mail@bernardcontrols.com
 Tel +49 22 41 98 340

ITALIA
BERNARD CONTROLS ITALIA
 MILAN

info.it@bernardcontrols.com
 Tel +39 02 931 85 233

KOREA (REPUBLIC OF)
BERNARD CONTROLS KOREA
 SEOUL

bck.info@bernardcontrols.com
 Tel +82 02-2270-3880

SINGAPORE
BERNARD CONTROLS SINGAPORE
 SINGAPORE

bcs.info@bernardcontrols.com
 Tel +65 65654227

SPAIN
BERNARD CONTROLS SPAIN
 MADRID

info.spain@bernardcontrols.com
 Tel +34 91 30 41 139

UNITED STATES
BERNARD CONTROLS Inc
 HOUSTON

bsales@bernardcontrols.com
 Tel +1 281 578 66 66

OFFICES

BANGKOK
BERNARD CONTROLS
SOUTH-EAST ASIA

j.chounramany@bernardcontrols.com
 Tel +66 2 640 82 64

DUBAI
BERNARD CONTROLS
MIDDLE-EAST

bernact@emirates.net.ae
 Tel +971 4 344 2010

MOSCOW
BERNARD CONTROLS
RUSSIA

youri.otradine@bernardcontrols.com
 Tel +(7 499) 251 06 54
 or +(7 916) 911 28 42

AGENTS AND DISTRIBUTORS

AMERICAS

Information on our network
 www.bernardcontrols.com

or
 Back Office
 BERNARD CONTROLS Inc.
 bsales@bernardcontrols.com
 Tel +1 281 578 66 66

BRAZIL

JCN
 SAO PAULO
 jcn@jcn.com.br
 Tel +55 11 39 02 26 00

ASIA

Information on our network
 www.bernardcontrols.com

or
 To contact our distributors
 Back Office
 BERNARD CONTROLS ASIA
 bcc.info@bernardcontrols.com
 Tel +86 10 6789 2861

EUROPE - MIDDLE EAST - AFRICA

Information on our network
 www.bernardcontrols.com

or
 Back Office
 BERNARD CONTROLS
 mail@bernardcontrols.com
 Tel +33 (0)1 34 07 71 00

or
 Contact directly agents/distributors

AUSTRIA

IPU ING PAUL UNGER
 WIEN
 hammermueller@IPU.co.at
 Tel +43 1 602 41 49

CZECH REPUBLIC

FLUIDTECHNIK BOHEMIA s.r.o.
 BRNO
 brno@fluidbohemia.cz
 Tel +420 548 213 233-5

DENMARK

ARMATEC A/S
 COPENHAGEN
 jo@armatec.dk
 Tel + 45 46 96 00 00

EGYPT

ATEB
 ALEXANDRIA
 gm@atebco.com
 Tel +203 582 76 47

FINLAND

TALLBERG TECH OY AB
 ESPOO
 info@tallberg.fr
 Tel +358 0 207 420 740

GREECE

PIGMS Entreprises Ltd
 ATHENS
 ioannis.pappas@pims.gr
 Tel +30 210 608 61 52

HUNGARY

APAGYI TRADEIMPEX KFT
 BUDAPEST
 bela.apagyi@mail.tvnet.hu
 Tel +36 1 223 1958

MOROCCO

AQUATEL sarl
 CASABLANCA
 aquatel@wanadoo.net.ma
 Tel +212 22 66 55 71

POLAND

ARNAP
 BIELSKO-BALA
 Sales@arnap.pl
 Tel +48 33 81 84004

POLAND

MARCO
 VARSOVIE
 matzanke@pol.pl
 Tel +48 22 864 55 43

SOUTH AFRICA

A-Q-RATE AUTOMATION CC
 BERTSHAM
 aqr@wol.co.za
 Tel +27 11 432 58 31

SWITZERLAND

MATOKEM AG
 ALLSCHWIL
 info@matokem.ag
 Tel +41 61 483 15 40

TURKEY

OTKONSAS
 ISTANBUL
 sales@otkonsas.com
 Tel +90 216 326 39 39

UNITED KINGDOM

ZOEDALE Plc
 BEDFORD
 enquiries@zoedale.co.uk
 Tel +44 12 34 83 28 28

Exhaustive list of agents
 and distributors on
www.bernardcontrols.com



//////////////////// Invest in Confidence ////////////////////////////////////// Invest in Confidence //////////////////////////////////////

BERNARD CONTROLS SA
 4 rue d'Arsonval - B.P. 70091
 95505 Gonesse CEDEX France
 Tel.: +33 (0)1 34 07 71 00
 Fax: +33 (0)1 34 07 71 01
 mail@bernardcontrols.com
 www.bernardcontrols.com

R105/04 All data in this brochure are given for information only and are subject to change without notice.



FAIL SAFE
ELECTRIC ACTUATORS
FQ RANGE

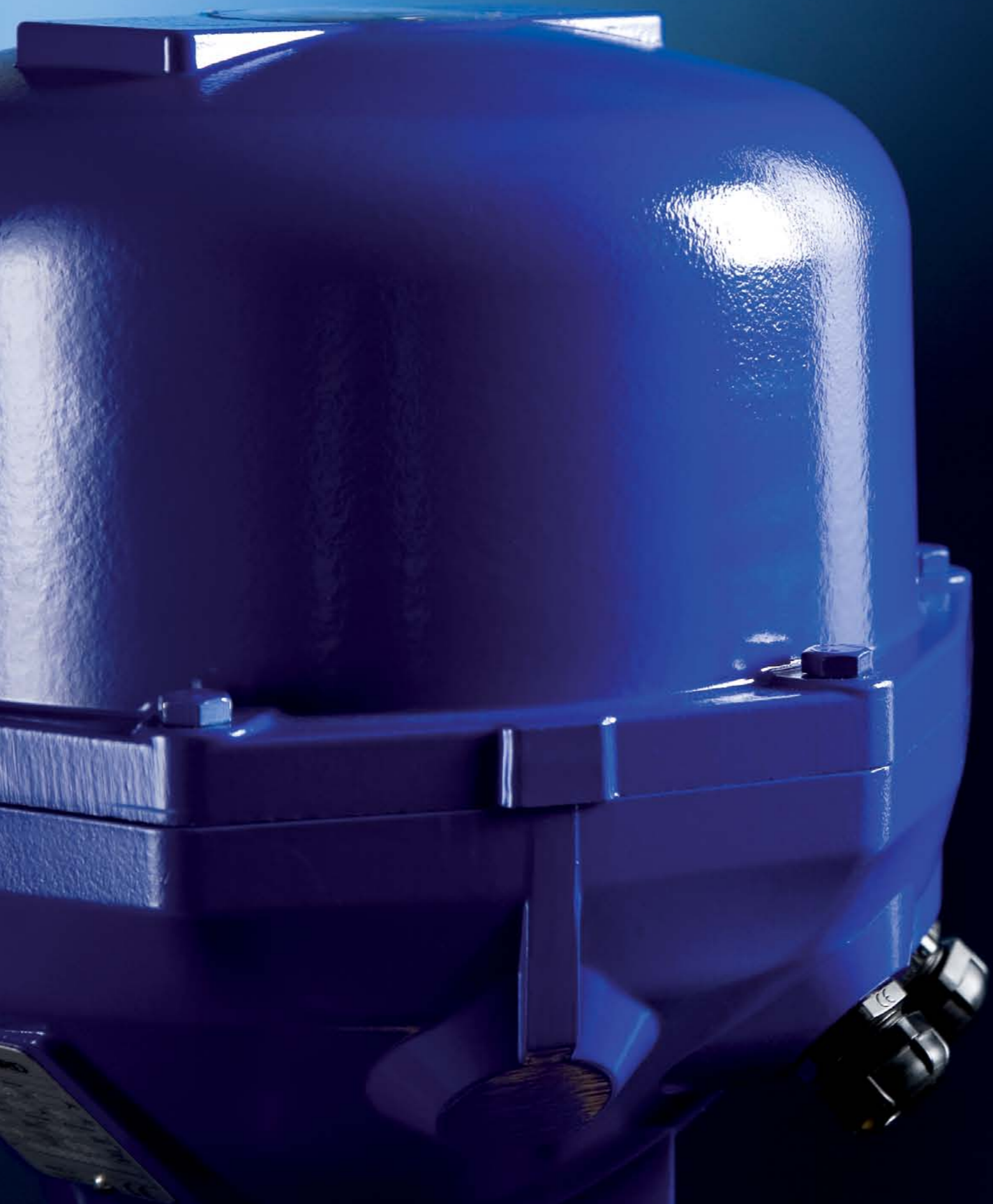

LABEL



- Reliability
- Security
- User Friendly

BERNARD CONTROLS introduces the BC Premium label. The BC Premium label is the guarantee of high performance, reliable and innovative actuator solutions designed to sustain severe environmental and operational conditions. Decades of return of experience from very demanding applications such as nuclear qualified valves actuation have shaped our technical orientations and our commitment to quality and safety. Moreover, BC Premium labeled products offer user-friendliness and extremely low level of maintenance requirements.

Contents

Fail safe electric actuators	> 4	Technical data	> 8	Standard mounting	> 18
Main features	> 6	Performances	> 12	Wiring diagram	> 19
		Dimensional drawings	> 16		

Failsafe electric actuators

For all quarter-turn applications, spring return FQ range actuators ensure automatic opening or closing even without any power supply.

> Operating principle

When energized, the actuator operates the valve normally and at the same time compresses the spring which is held in the loaded position by a solenoid brake.

In case of power failure to the solenoid, the spring will drive the actuator and valve to the safety position either open or closed. The associated dashpot speed controls the spring action and allows a safe and shockfree operation of the valve.

When the power supply is restored (no resetting of the spring is required), the actuator is immediately available for normal operation.

In standard, the spring operates clockwise when viewed from the top. The electric part is equipped with an asynchronous three-phase motor of squirrel cage type. Other versions are available in single phase and direct current supply.

> Application fields

All applications where the loss of power supply requires automatically to put the driven device in a safety position.

All applications where the risks are such, that driving the device to its safety position must be possible at any time even in the absence of power supply.



For example :

- Storage and distribution of gas and dangerous fluids
- Refineries trucks loading arms
- Fire protection systems
- Chemical installation safety
- Climate control and ventilation on hazardous areas
- Ventilation of hazardous areas



BERNARD CONTROLS
 TYPE TYP F012
 Moteur - Motor
 0.03 KW 230 V 1 Ph
 30 % 0.5 A 50 Hz
 Actionneur - Antrieb - Actuator
 120 Nm / 0 120 Nm
 0.18 w/min 0.25 tours umdr. rpm turns
 N° 09L08363 001
 MADE IN FRANCE CE

Main features

For all quarter turn applications, spring return FQ range actuators ensure automatic opening or closing even without any power supply.

➤ Easy to use, maintenance free

- No periodic maintenance required.
- Trouble free operation for years (the FQ system is not battery technology based).
- Spring efficiency guaranteed over the full 90° travel.
- Fast and shock-free operation of the valve during emergency closing / opening.
- Travel limit switches easy to set with a simple screw driver and unaffected by mechanical vibrations effects.
- Easy access to electrical connections via a terminal strip.

FQ actuator is supplied complete with:

- Mechanical position indicator
- Adjustable quarter-turn mechanical stops
- 2 travel limit switches setting easy, with a simple screw driver
- Electrical connection to a terminal strip
- Emergency handwheel on all models (excepted the FQ04 and the FQ08)

FQ actuators are available as:

- On-Off: Maximum recommended 20-30 full stroke travels per day. 30% motor service duty.
- Class III: Modulating intermediate positioning with a precision better than 2%. Maximum recommended: 360 movements per day. 50% motor service duty.



What is Fail Safe?

The activation of an emergency signal triggers the immediate opening or closing of the backup device, without the need of any external power source and using a full mechanical spring return.

This signal can be activated following:

- An abnormal event (fire, overflow ...)
- An automatic control
- An operator's action
- A lack of power supply

➤ Enclosures

FQ actuators are weather-proof to IP67 and are also available as explosion-proof according to international standards.

➤ Possible options

- Motor:
 - 3PH 50 or 60 Hz
 - 1PH 50 or 60 Hz
 - DC – versions
- On/Off or Positioning
 - Advanced controls with local buttons
 - INTEGRAL+ (On/Off)
 - POSIGAM+ (Positioning)
- Extra limit switches
- Anticondensation heater resistor
- Position transmitters : 4-20mA or potentiometer
- Solenoid brake
 - 115V AC
 - 230V AC
 - DC version
- Fast spring return
- Clockwise or counterclockwise spring action



Technical data

General specifications

General specifications	Torque range	Quarter-turn, direct mounting from 40 to 500Nm
	Modulating class	On-off or class III
Enclosure	Enclosure	Cast aluminium
	Waterproofness	IP67
	Programming	FQ range is generally proposed with standard control (camblock + end-of-travel switches). INTEGRAL+ & POSIGAM+ (See INTEGRAL+ catalogue) advanced controls are also possible with separated control box. Maximum distance between control box and actuator: 50m
	Explosion proof ATEX (option)	ATEX Directive 94/9/EC - CENELEC EN 50014, EN 50018 As standard: EEx d IIC T4 (option T5 or T6) - Ex II 2 G Certificate : LCIE 02 ATEX 6902
	Ambient temperature operating range	EEx d IIC T4 : -20°C to 70°C (-40°C in option) EEx d IIC T5 : -20°C to 65°C (-40°C in option) EEx d IIC T6 : -20°C to 50°C (-40°C in option)
	Explosion proof C.S.A. (Canada & USA) (option)	NEMA 7 - NEMA 9 certified C22-2, FM3600, FM3611 and FM3615 standards Class I Group C, D div 1&2 (option Group B) Class II Group E, F, G div 1&2 Certificate : 1061444
	External corrosion protection	Standard paint system: Zinc rich primer, epoxy undercoat and RAL5002 blue protection polyurethane top coat. Optional special anti-corrosion protection for marine, aggressive or abrasive atmospheres. All cover fasteners captive and stainless.
Motor	Motor technology	TEPV type (Totally Enclosed Non Ventilated). Class F insulation class. Integrated thermal overload protection.
	Motor duty rating	S4 motor service (Intermittent periodic duty with startings) to IEC 34-1 • S4 - 30% for ON/OFF operation - up to 360 starts per hour. • S4 - 50% for Modulating class III - up to 1,200 starts per hour.
Mechanical specifications	Gearing	Self-locking
	Manual override	Function available on FQ12, FQ18, FQ30 and FQ50. Handwheel does not rotate during motor operation. Padlockable clutch lever.
	Spring return	CW as standard, CCW on request (non reversible device) Fast spring return in option
	Output flange	Flange comply with ISO 5211 (Optionnal standard flange on FQ04 to FQ18).
	Output drive	Direct output drive on FQ04 to FQ18 (Removable socket in option). Removable socket on FQ30 and FQ50.
	Vibration Resistance	1g (9.8 m/s ²) at 10-500 Hz For higher vibration resistance, please contact us.
Lubrication	Actuators are lubricated for product lifetime and do not require any specific periodic maintenance	

Electrical specifications	Power supply	Actuators are available for a wide range of power supplies: • Single-phase, three-phase or DC voltages • 50 ou 60 Hz • Specific voltages on request
	Cable entries	Standard configuration (other on request): 3xM20 • 2 for signalling, • 1 for power supply
	Solenoid brake	The solenoid rated power is 21 W. This solenoid is normally under permanent power supply. Need separated power supply. Nominal voltage: • 230V AC for 230V or 400V AC actuators • 115V AC for 115V or 460V AC actuators • 24V DC for 24V DC actuators Other possible voltages on request
	Position sensors	• Movement read directly on the main shaft (direct mechanical link) • Adjustable camblock with 2 SPDT end-of-travel switches • 2 extra position switches in option • Independent position transmitter (TAM or potentiometer) in option

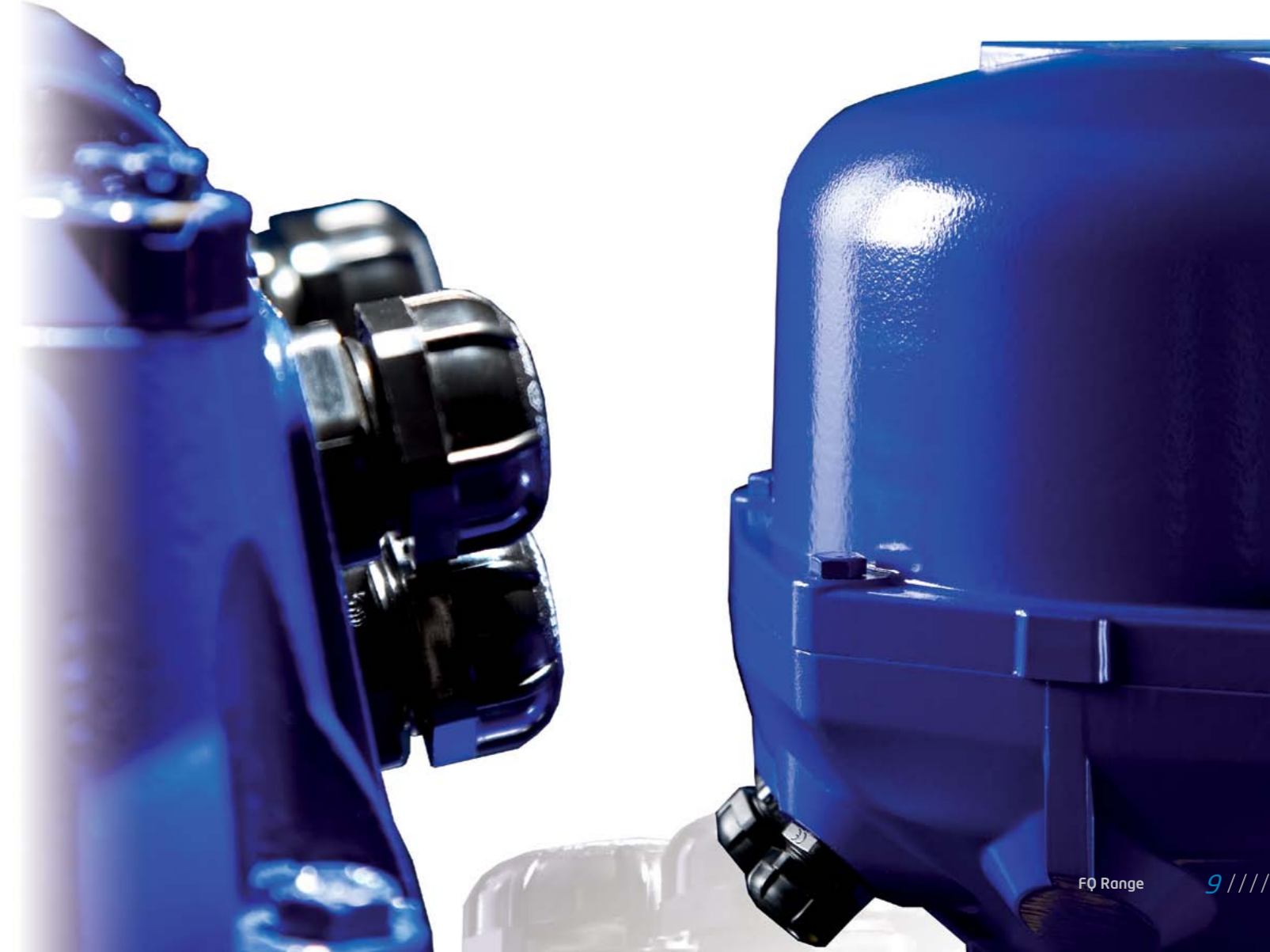

Advanced controls (option)	Models	Two versions according to operating modes: INTEGRAL+ for ON/OFF which includes : <ul style="list-style-type: none"> • Terminal compartment • Power contactors • Logic control • Configuration panel • Signalling relays • Local control selectors POSIGAM+ for Class III positioning : <ul style="list-style-type: none"> • All INTEGRAL+ features • Positioner board • Position feedback
	Enclosure protection	Separated FPi box (weatherproof design) <ul style="list-style-type: none"> • Standard: IP67 / NEMA 4 Separated FPx box (explosionproof design) <ul style="list-style-type: none"> • Standard: IP67 / EEx d IIC T6 - NEMA 7 / 9
	On-off control	<ul style="list-style-type: none"> • Isolated by opto-couplers • Voltage: 10 to 250 V DC/AC • Current: 10 mA at 24V • Dry contacts (uses INTEGRAL+ auxiliary DC supply) • Minimum pulse duration: 100ms • Time of rotational direction change: 50ms or 200ms
	Positioning control	<ul style="list-style-type: none"> • Standard : Input signal 4-20 mA - Output signal 4-20 mA • On request : Input signal 0-20 mA - Output signal 0-20 mA • On request : Input signal 0-10 V - Output signal 0-20 mA
	Signaling relays	<ul style="list-style-type: none"> • 4 relays: 4 datas can be freely selected among a total of 16 available datas (250VAC-5A max.) • 1 fault relay
	Cable entries	Standard configuration (other on request): 3xM20 (2 for signalling, 1 for power supply)
	EU conformity	INTEGRAL+ / POSIGAM+ controls complying with: <ul style="list-style-type: none"> • The 2004/108/EC electromagnetic compatibility • The 2006/95/EC low voltage • The following harmonized standards: Generic emission standard-Industrial environment EN 61000-6-4 Generic immunity standard - Industrial environment EN 61000-6-2. Degrees of protection provided by enclosures (IP code) EN 60529
	Vibration resistance	1g (9.8 m/s ²) at 10-500 Hz
ADDITIONAL OPTIONS	Fieldbus interface (option)	Profibus DP (single or redundant) <ul style="list-style-type: none"> • PROFIBUS-DP slave - RS 485 • Baudrate: autodetection • Total number of master and slave modules on the same line: 31 max. up to 99 with repeaters • PROFIBUS operability approved by PNO (Profibus Nutzer Organisation) • External power supply backup
	Additional options	<ul style="list-style-type: none"> • LED indication board (closed, open, power on) • Additional 3 relays board • Additional position transmitter isolated from the other output signals

Performances

> ON/OFF

3 PH 400V 50 Hz ON/OFF											
Max Torque	Type	Operating time 90°/sec			Flange	Motor : S4 service - D.R. : 30%					
		Motor		Spring		Power	Speed	Current	Current	Cos	Efficiency
		Sec	Fast	Std							
40	FQ04	14	3	7	F07	0,06	3000	0,3	0,9	0,8	43
40	FQ04	33	3	7	F07	0,06	3000	0,3	0,9	0,8	43
80	FQ08	33	2	6	F07	0,06	3000	0,3	0,9	0,8	43
120	FQ12	39	2	10	F10	0,06	3000	0,3	0,9	0,8	43
120	FQ12	93	2	10	F10	0,06	3000	0,3	0,9	0,8	43
180	FQ18	93	3	15	F10	0,06	3000	0,3	0,9	0,8	43
300	FQ30	117	7	18	F14	0,06	3000	0,3	0,9	0,8	43
500	FQ50	117	9	27	F14	0,06	3000	0,3	0,9	0,8	43

3 PH 460V 60 Hz ON/OFF											
Max Torque	Type	Operating time 90°/sec			Flange	Motor : S4 service - D.R. : 30%					
		Motor		Spring		Power	Speed	Current	Current	Cos	Efficiency
		Sec	Fast	Std							
40	FQ04	12	3	7	F07	0,07	3600	0,3	0,9	0,8	43
40	FQ04	28	3	7	F07	0,07	3600	0,3	0,9	0,8	43
80	FQ08	28	2	6	F07	0,07	3600	0,3	0,9	0,8	43
120	FQ12	33	2	10	F10	0,07	3600	0,3	0,9	0,8	43
120	FQ12	78	2	10	F10	0,07	3600	0,3	0,9	0,8	43
180	FQ18	78	3	15	F10	0,07	3600	0,3	0,9	0,8	43
300	FQ30	98	7	18	F14	0,07	3600	0,3	0,9	0,8	43
500	FQ50	98	9	27	F14	0,07	3600	0,3	0,9	0,8	43

1 PH 230V 50 Hz ON/OFF											
Max Torque	Type	Operating time 90°/sec			Flange	Motor : S4 service - D.R. : 30%					
		Motor		Spring		Power	Speed	Current	Current	Cos	Efficiency
		Sec	Fast	Std							
40	FQ04	33	3	7	F07	0,03	3000	0,5	1,1	0,9	25
80	FQ08	33	2	6	F07	0,03	3000	0,5	1,1	0,9	25
120	FQ12	93	2	10	F10	0,03	3000	0,5	1,1	0,9	25
180	FQ18	93	3	15	F10	0,03	3000	0,5	1,1	0,9	25
300	FQ30	117	7	18	F14	0,03	3000	0,5	1,1	0,9	25

Please note: The operating time of the spring can increase according to the load.
The mentioned operating times refer to the max output torque.

1 PH 115V 60 Hz ON/OFF											
Max Torque	Type	Operating time 90°/sec			Flange	Motor : S4 service - D.R. : 30%					
		Motor		Spring		Power	Speed	Current	Current	Cos	Efficiency
		Sec	Fast	Std							
40	FQ04	28	3	7	F07	0,03	3600	0,7	2,6	0,9	40
80	FQ08	28	2	6	F07	0,03	3600	0,7	2,6	0,9	40
120	FQ12	78	2	10	F10	0,03	3600	0,7	2,6	0,9	40
180	FQ18	78	3	15	F10	0,03	3600	0,7	2,6	0,9	40
300	FQ30	98	7	18	F14	0,03	3600	0,7	2,6	0,9	40

24V DC ON/OFF											
Max Torque	Type	Operating time 90°/sec			Flange	Motor : S4 service - D.R. : 30%					
		Motor		Spring		Power	Speed	Current	Current	Cos	Efficiency
		Sec	Fast	Std							
40	FQ04	30	3	7	F07	0,027	3000	2	7		66
80	FQ08	40	2	6	F07	0,027	3000	3	7		66
120	FQ12	100	2	10	F10	0,027	3000	2	7		66
180	FQ18	110	3	15	F10	0,027	3000	2	7		66
300	FQ30	150	7	18	F14	0,027	3000	3	7		66

> CLASS III

3 PH 400V 50 Hz Class III												
Max Torque	Permanent Torque	Type	Operating time 90°/sec			Flange	Motor : S4 service - D.R. : 50%					
			Motor		Spring		Power	Speed	Current	Current	Cos	Efficiency
			Sec	Fast	Std							
40	20	FQ04	26	3	7	F07	0,03	1500	0,3	0,4	0,8	14
40	20	FQ04	61	3	7	F07	0,03	1500	0,3	0,4	0,8	14
80	40	FQ08	61	2	6	F07	0,03	1500	0,3	0,4	0,8	14
120	60	FQ12	78	2	10	F10	0,03	1500	0,3	0,4	0,8	14
120	60	FQ12	184	2	10	F10	0,03	1500	0,3	0,4	0,8	14
180	90	FQ18	184	3	15	F10	0,03	1500	0,3	0,4	0,8	14
300	150	FQ30	233	7	18	F14	0,03	1500	0,3	0,4	0,8	14
500	250	FQ50	233	9	27	F14	0,03	1500	0,3	0,4	0,8	14

Please note: The operating time of the spring can increase according to the load.
The mentioned operating times refer to the max output torque.

> CLASS III

3 PH 460V 60 Hz Class III												
Max	Permanent	Type	Operating time 90°/sec			Flange	Motor : S4 service - D.R. : 50%					
Torque	Torque		Motor	Spring			Power	Speed	Current	Current	Cos	Efficiency
Nm	Nm		Sec	Fast	Std	ISO	kW	rpm	rated A	start A	Φ	%
40	20	FQ04	22	3	7	F07	0,04	1800	0,3	0,4	0,9	14
40	20	FQ04	51	3	7	F07	0,04	1800	0,3	0,4	0,9	14
80	40	FQ08	51	2	6	F07	0,04	1800	0,3	0,4	0,9	14
120	60	FQ12	65	2	10	F10	0,04	1800	0,3	0,4	0,9	14
120	60	FQ12	154	2	10	F10	0,04	1800	0,3	0,4	0,9	14
180	90	FQ18	154	3	15	F10	0,04	1800	0,3	0,4	0,9	14
300	150	FQ30	194	7	18	F14	0,04	1800	0,3	0,4	0,9	14
500	250	FQ50	194	9	27	F14	0,04	1800	0,3	0,4	0,9	14

1 PH 230V 50 Hz Class III												
Max	Permanent	Type	Operating time 90°/sec			Flange	Motor : S4 service - D.R. : 50%					
Torque	Torque		Motor	Spring			Power	Speed	Current	Current	Cos	Efficiency
Nm	Nm		Sec	Fast	Std	ISO	kW	rpm	rated A	start A	Φ	%
40	20	FQ04	66	3	7	F07	0,02	1500	0,5	0,7	0,9	13
80	40	FQ08	66	2	6	F07	0,02	1500	0,5	0,7	0,9	13
120	60	FQ12	184	2	10	F10	0,02	1500	0,5	0,7	0,9	13
180	90	FQ18	184	3	15	F10	0,02	1500	0,5	0,7	0,9	13
300	150	FQ30	233	7	18	F14	0,02	1500	0,5	0,7	0,9	13

1 PH 115V 60 Hz Class III												
Max	Permanent	Type	Operating time 90°/sec			Flange	Motor : S4 service - D.R. : 50%					
Torque	Torque		Motor	Spring			Power	Speed	Current	Current	Cos	Efficiency
Nm	Nm		Sec	Fast	Std	ISO	kW	rpm	rated A	start A	Φ	%
40	20	FQ04	55	3	7	F07	0,03	1800	1	1,2	0,9	20
80	40	FQ08	55	2	6	F07	0,03	1800	1	1,2	0,9	20
120	60	FQ12	154	2	10	F10	0,03	1800	1	1,2	0,9	20
180	90	FQ18	154	3	15	F10	0,03	1800	1	1,2	0,9	20
300	150	FQ30	194	7	18	F14	0,03	1800	1	1,2	0,9	20

Please note: The operating time of the spring can increase according to the load.
The mentioned operating times refer to the max output torque.

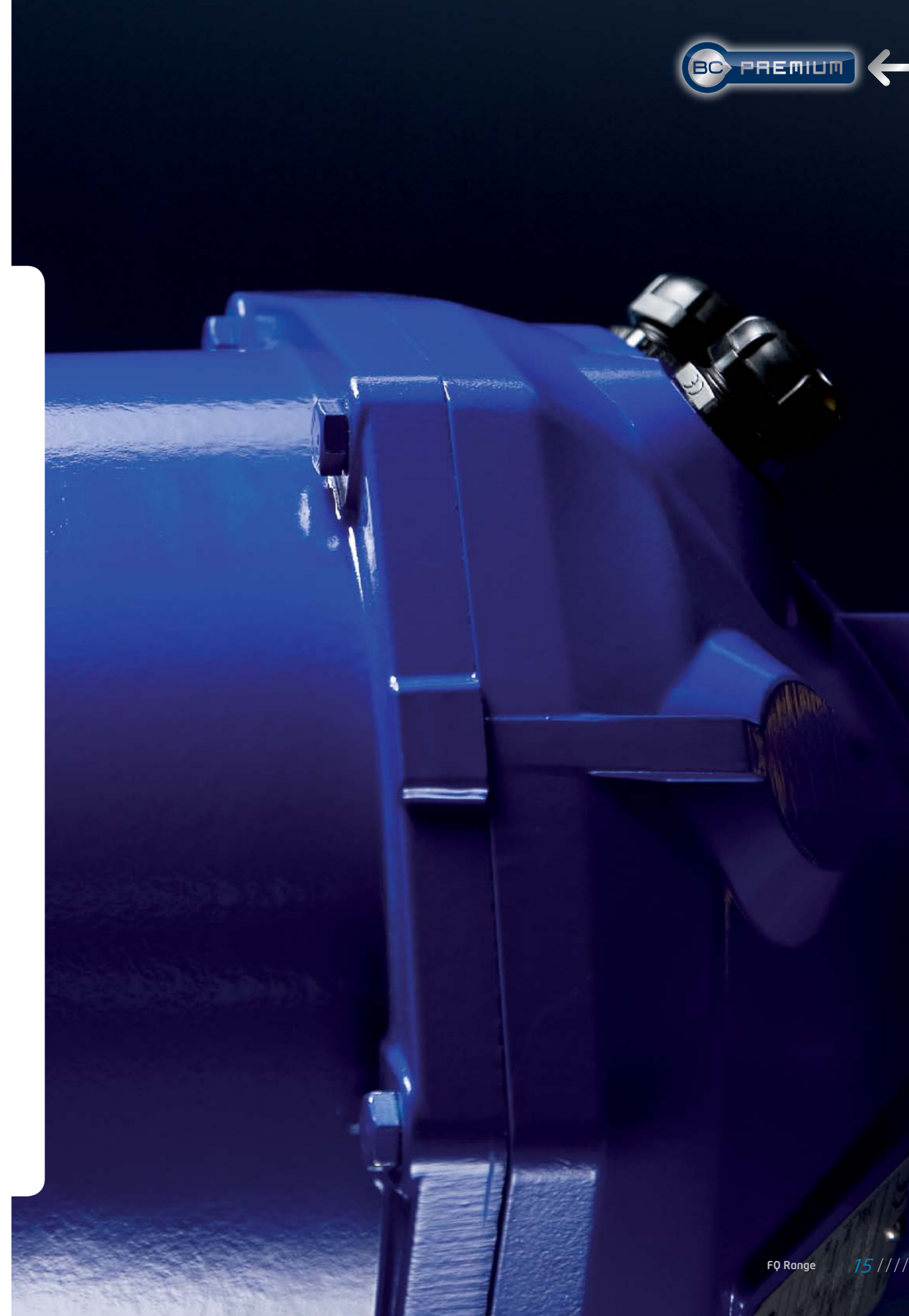

Dimensional drawings

> FQ04 & FQ08

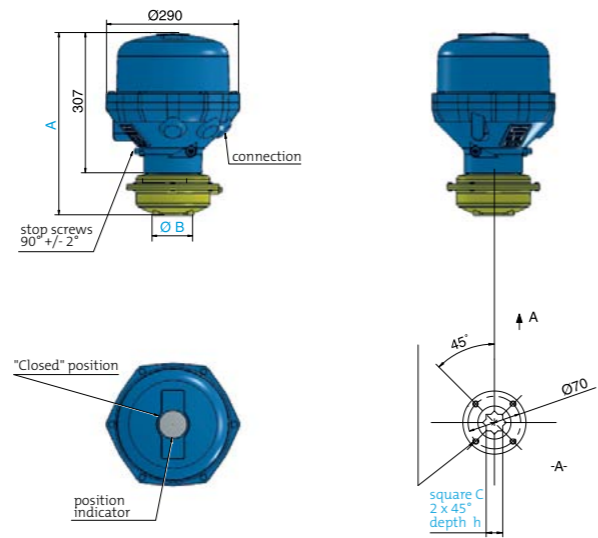

Type	A	Ø B	Square C	h	Weight
FQ04	386	Ø 84	17	19	25 kg
FQ08	396	Ø 117	22	24	30 kg

> FQ12 & FQ18

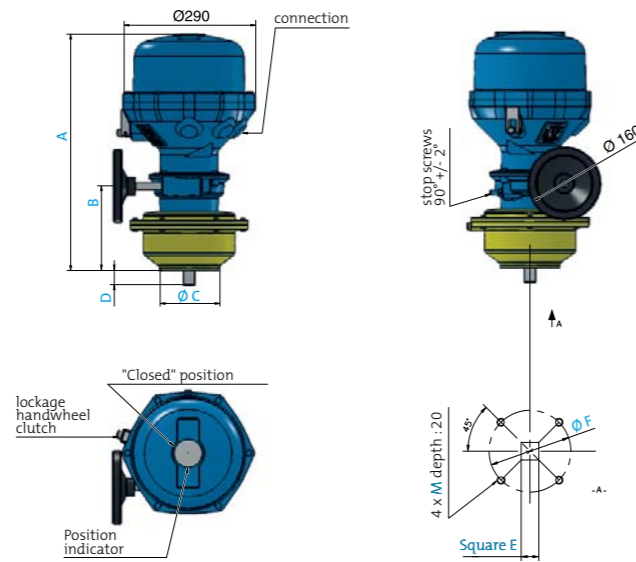

Type	A	B	Ø C	D	Square E	Ø F	M	Weight
FQ12	500	167	Ø 117	25	22	Ø 102	M10	40 kg
FQ18	518	185	Ø 130	31	25	Ø 78	M12	45 kg



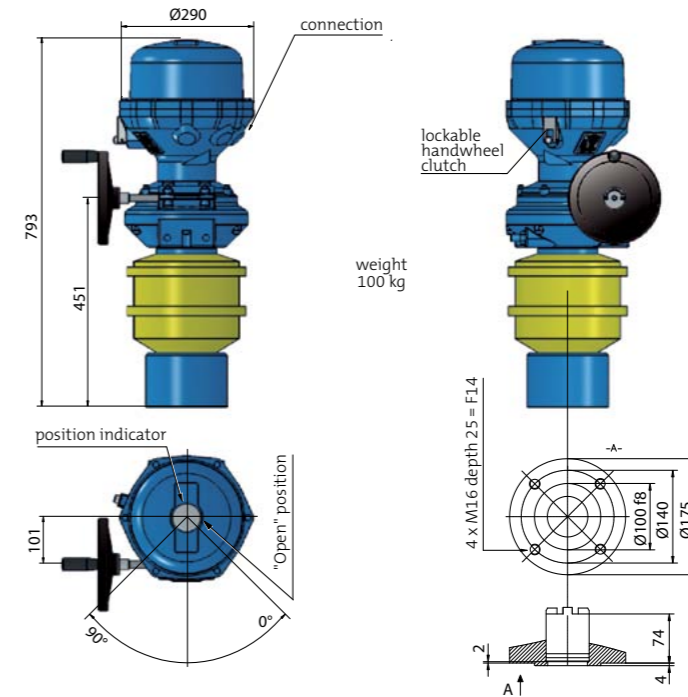

> FQ30

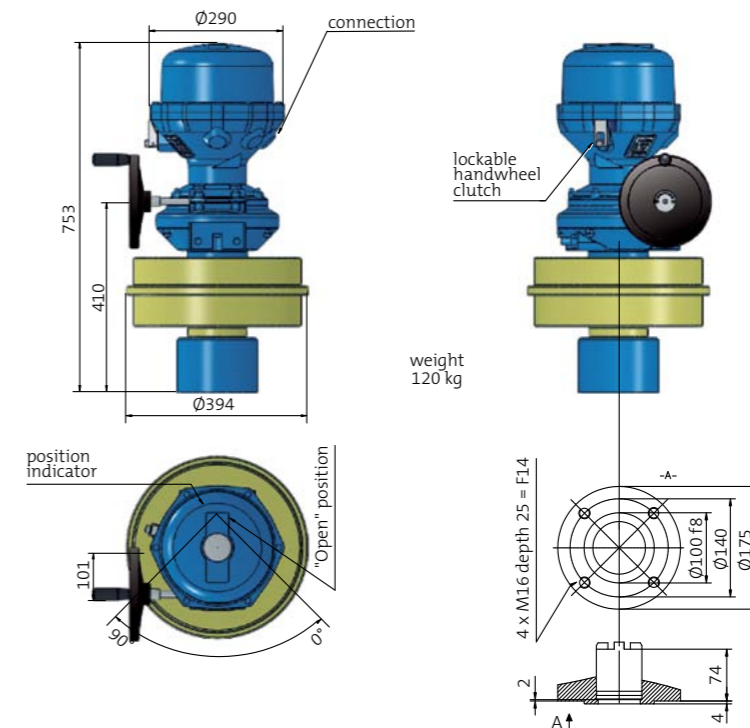

> FQ50

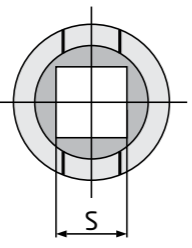
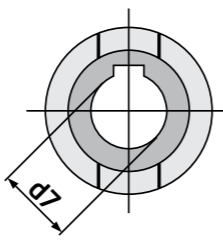
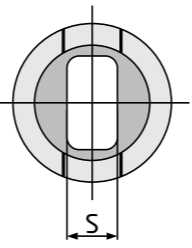
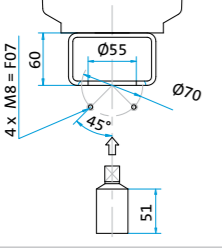
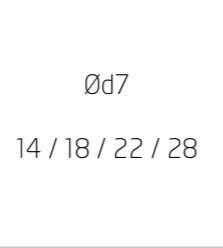
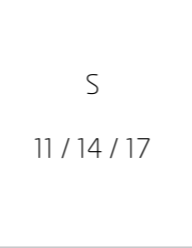
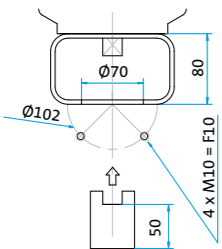
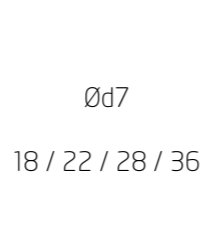
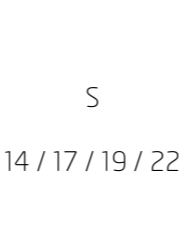
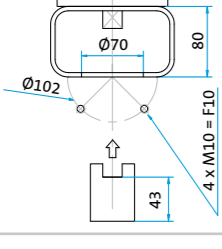
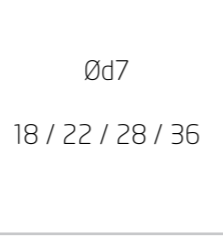

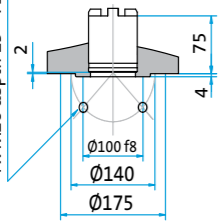
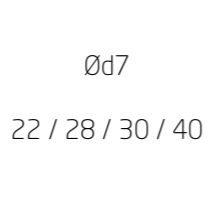
Standard mounting

	PARALLEL SQUARE	KEY	FLAT
FQ04			
	S	Ød7	S
	11 / 14 / 17	14 / 18 / 22 / 28	11 / 14 / 17
FQ08			
	S	Ød7	S
	11 / 14 / 17	14 / 18 / 22 / 28	11 / 14 / 17
FQ12			
	S	Ød7	S
	14 / 17 / 19 / 22	18 / 22 / 28 / 36	14 / 17 / 19 / 22
FQ18			
	S	Ød7	S
	14 / 17 / 19 / 22	18 / 22 / 28 / 36	14 / 17 / 19 / 22
FQ30 & FQ50			
	S	Ød7	S
	19 / 22 / 36	22 / 28 / 30 / 40	19 / 22 / 36

Standard wiring diagram

ACTUATOR

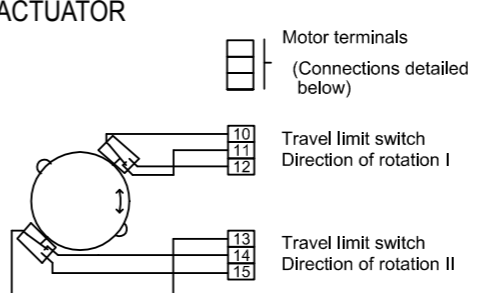

Motor terminals (Connections detailed below)

Travel limit switch Direction of rotation I (Terminals 10, 11, 12)

Travel limit switch Direction of rotation II (Terminals 13, 14, 15)

FUNCTION OF SWITCHES
 Direction of rotation
 I) Counterclockwise (normally opening)
 II) Clockwise (Normally closing)

Direction of rotation seen on opposite side of fixing flange of actuator

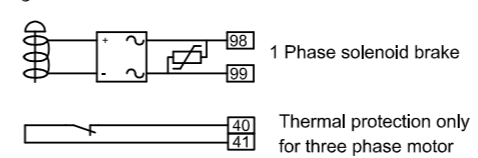

1 Phase solenoid brake (Terminals 98, 99)

Thermal protection only for three phase motor (Terminals 40, 41)

SOLENOID OPERATED BRAKE CONNECTION INSTRUCTIONS

- Do not connect the solenoid operated brake (terminals 98 & 99).
- Connect terminals 1,2,3 to give supply to the motor and check the rotation direction.
- Connect the travel limit switches and check its function.
- Now connect the solenoid operated brake if all other operations have been given satisfactory.

Voltages table

MOTOR	Solenoid Operated Brake
3Ph 460V-60Hz	115V
3Ph 400V-50Hz	230V
1Ph 230V-50Hz	230V
1Ph 115V-60Hz	115V
24V DC	24V DC

OPTIONAL ACCESSORIES

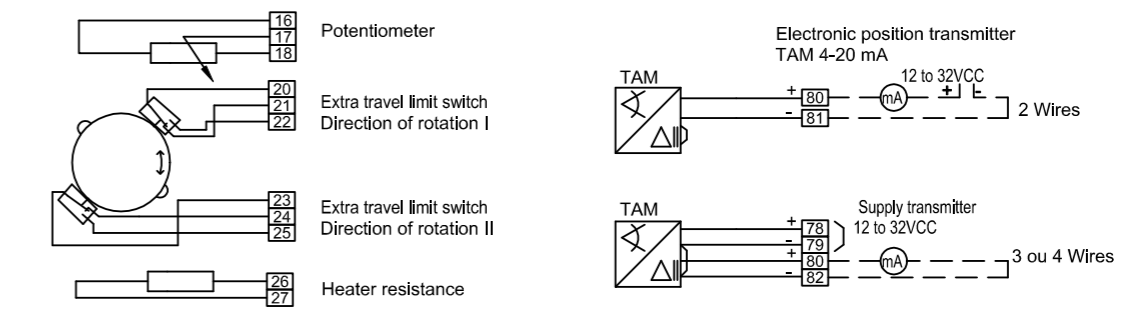

Potentiometer (Terminals 16, 17, 18)

Extra travel limit switch Direction of rotation I (Terminals 20, 21, 22)

Extra travel limit switch Direction of rotation II (Terminals 23, 24, 25)

Heater resistance (Terminals 26, 27)

Electronic position transmitter TAM 4-20 mA (Terminals 80, 81, 82)

Supply transmitter 12 to 32VCC (Terminals 78, 79, 80, 82)

MOTOR

THREE PHASE

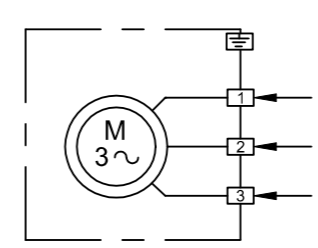

SINGLE PHASE

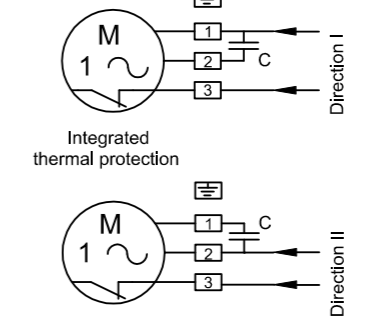

Integrated thermal protection

DC

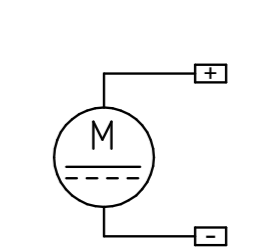

NOTA: 3Ph phase direct = Direction II