

KUEBLER - WIRE ENCODERS A50

SERIE D8.6A1

- Max measuring length 1 250 mm
- -20 to +85 °C
- Titanium anodized aluminum housing
- Compact dimensions



PRODUCT DESCRIPTION

The Kübler Miniature Wire Giver A50 is designed for simpler applications with lower speeds. The housing can be combined with digital and analogue encoder. Maximum wire length is 1250mm.

Please refer to the images below for ordering information.

Order code with encoder (incremental, absolute)		D 8.6 A 1 . XXXX . XX X X . XXXX					Standard variants are represented bold underlined>
		Type	a	b	c	d	e
a Measuring range	b Encoder used						
0025 = 250 mm	36 = Sendix 3610, incremental						
0050 = 500 mm	M3 = Sendix M3663, absolute, SSI						
0125 = 1250 mm	F3 = Sendix F3663, absolute, SSI						
	M8 = Sendix M3668, absolute, CANopen						
	F8 = Sendix F3668, absolute, CANopen						
	c Output circuit						
	depends on the encoder used						
	d Type of connection						
	depends on the encoder used						
	e Resolution / Protocol / Options						
	depends on the encoder used						
	Optional on request						
	- Other measuring ranges						
	- Eyelet or M4 wire fastening instead of wire clip						
	- Modified cable and/or connector orientation						
	- Modified cable outlet direction						
	- Sensor protection level IP67						
	- Improved linearity (0.02 %)						

Standard resolutions for draw wire with incremental encoder Sendix 3610				Standard resolutions for draw wire with absolute encoder Sendix F3663/M3663 (12 bit ST) or F3668/M3668 (12 bit ST, programmable via bus)	
Drum circumference [mm]	125	125	125	Drum circumference [mm]	125
Pulses / revolution [ppr]	125	1250	2500	Pulses / revolution [ppr]	4096
Pulses / mm	1	10	20	Pulses / mm	32.8
Resolution [mm]	1	0.1	0.05	Resolution [mm]	0.03

Order code with analog sensor (scaled to measuring range)		D 8.3 A 1 . XXXX . XXX X . 0000			
		Type	a	b	c
a Measuring range	b Analog sensor output / power supply				
0025 = 250 mm	A11 = 4 ... 20 mA / 12 ... 30 V DC				
0050 = 500 mm	A22 = 0 ... 10 V / 12 ... 30 V DC				
0125 = 1250 mm	A33 = potentiometer 1 kΩ / max. 30 V DC				
	c Type of connection				
	1 = axial cable, 2 m PVC				
	3 = axial M12 connector, 4-pin				
	Optional on request				
	- Other measuring ranges				
	- Eyelet or M4 wire fastening instead of wire clip				
	- Modified cable and/or connector orientation				
	- Modified cable outlet direction				
	- Sensor protection level IP67				
	- Improved linearity (0.02 %)				
	- Increased temperature range -40°C ... +85°C and -20°C ... +120°C				

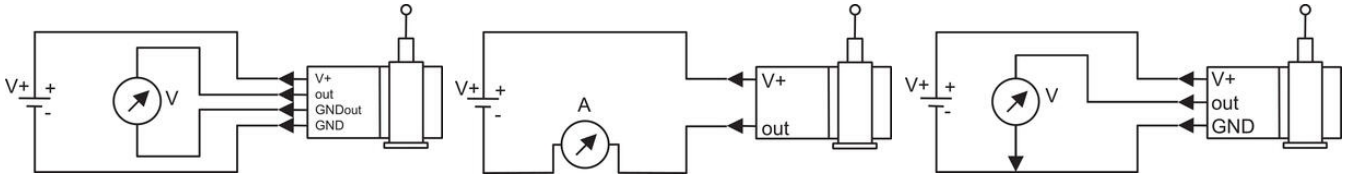

Pin	1	2	3	4
Cable colour	brown	white	blue	black
0...10V	V+	Signal	GND	GND Sig.
4...20 mA	V+	n. c.	Signal	n. c.
1kOhm	V+	Slider	GND	n. c.

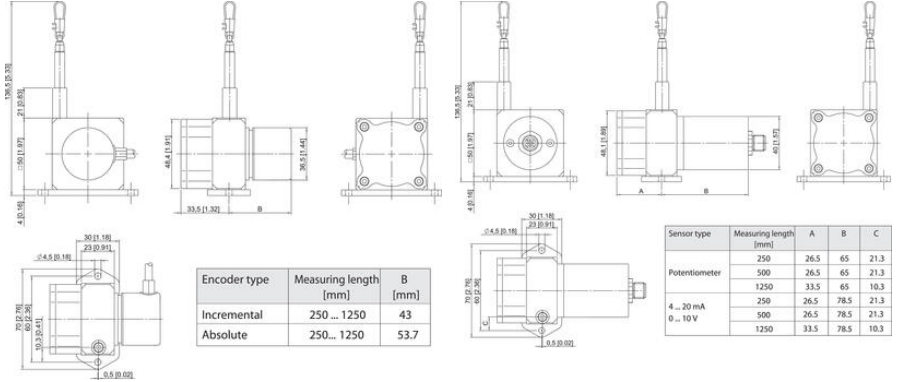
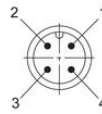

Encoder type	Measuring length [mm]	B [mm]
Incremental	250...1250	43
Absolute	250...1250	53.7

Sensor type	Measuring length [mm]	A	B	C
Potentiometer	250	26.5	65	21.3
	500	26.5	65	21.3
	1250	33.5	65	10.3
4...20 mA 0...10V	250	26.5	78.5	21.3
	500	26.5	78.5	21.3
	1250	33.5	78.5	10.3

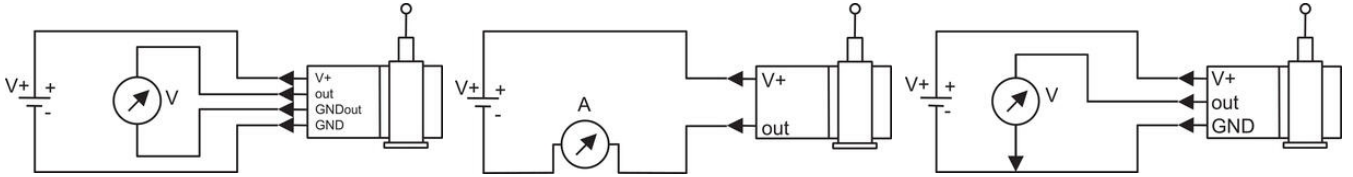

Pin	1	2	3	4
Cable colour	brown	white	blue	black
0...10V	V+	Signal	GND	GND Sig.
4...20 mA	V+	n. c.	Signal	n. c.
1kOhm	V+	Slider	GND	n. c.

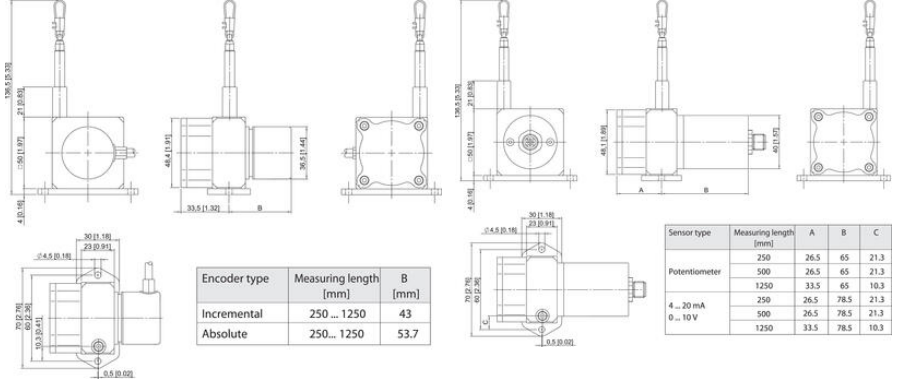
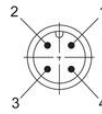

Encoder type	Measuring length [mm]	B [mm]
Incremental	250...1250	43
Absolute	250...1250	53.7

Sensor type	Measuring length [mm]	A	B	C
Potentiometer	250	26.5	65	21.3
	500	26.5	65	21.3
	1250	33.5	65	10.3
4...20 mA 0...10V	250	26.5	78.5	21.3
	500	26.5	78.5	21.3
	1250	33.5	78.5	10.3