

CROUZET SWITCHES - 83132 DOUBLE BREAKING MINIATURE

83132030
831320 D/BRK W2

- Double breaking function/two-pole microswitch
- Connections in three different directions
- Option of actuating several switches in the same control movement

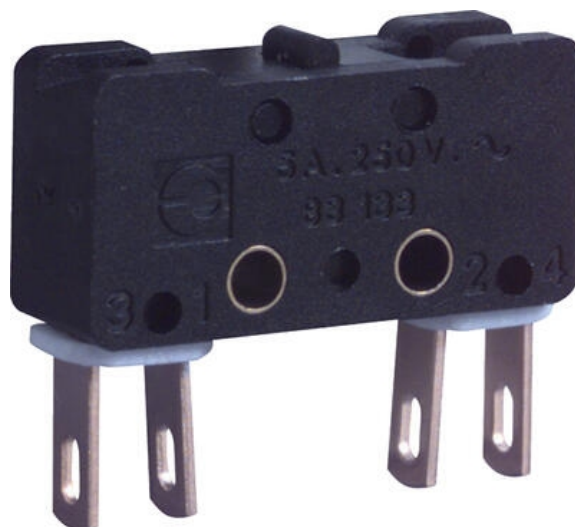

PRODUCT DESCRIPTION

SPECIFICATIONS

Allowable Operating Force Max	10
Contact gap	0,3 x 2 mm
Hysteresis Max	0.45
IP Class	IP40
Operating Force Max	1.6
Over Movement My	0.27
Rated current at 250 V AC	6
Return Movement Force Min	0.4
Sleep Max	8.45
Switching Point	7,7±0,2 mm
Temperature range from	-40
Temperature range to	125
Thermal current at 250 V AC	10

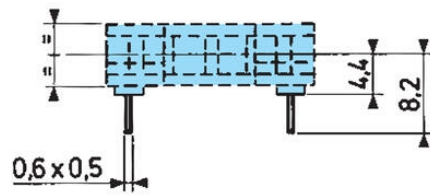
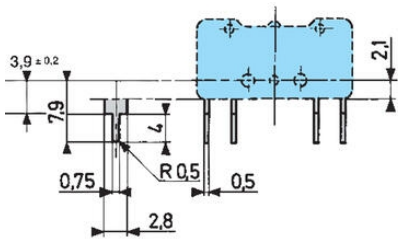

54B

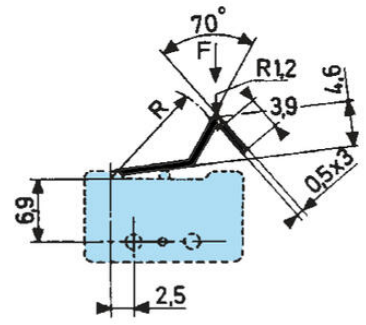

54A2

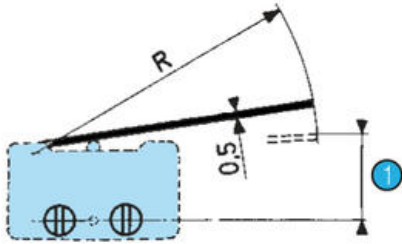

54A3

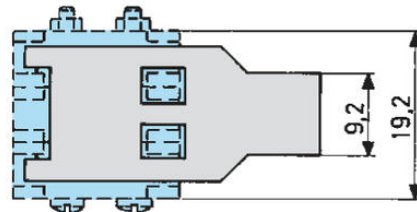

For 83 132 0 och 83 133 0

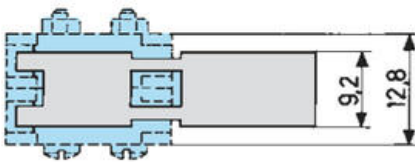
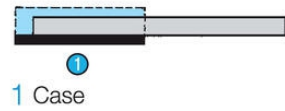

1 Switching point

For 83 134 0

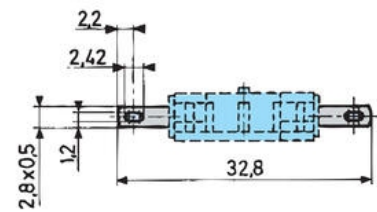
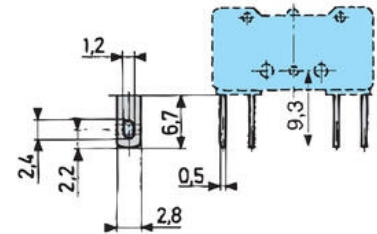
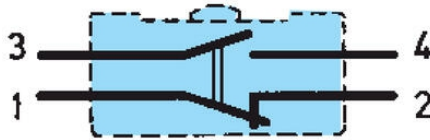
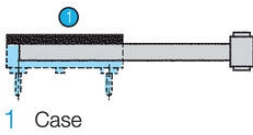

83 132 0

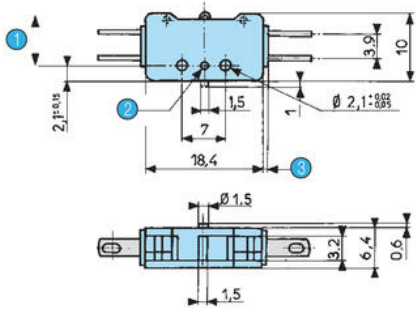

- 1 OL = 7.4
- 2 Ø1.5 depth 0.7
- 3 2 plates 0.8

83 133 0

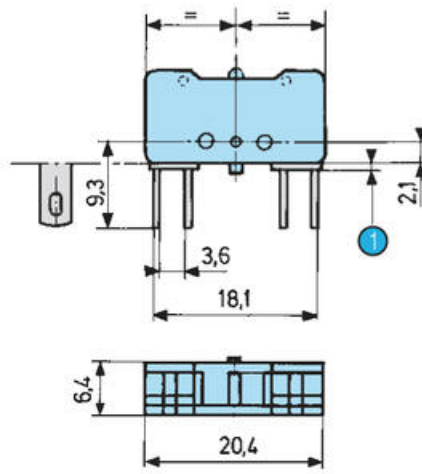

1 2 plates 0.8

54E

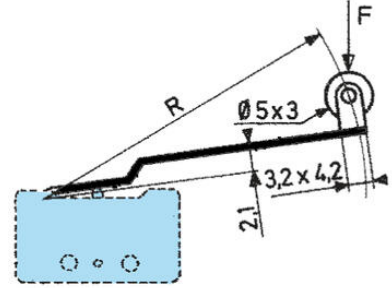

54A

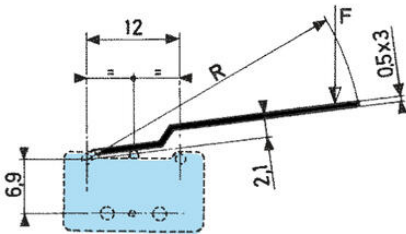

Operating curve for type
83 132 0 - 83 133 0 - 83 134 0

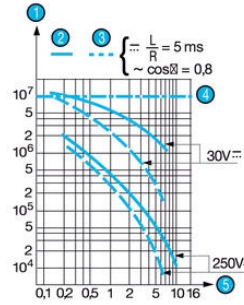

- 1 Number of cycles
- 2 Resistive load
- 3 Inductive load
- 4 Mechanical life
- 5 Current (A)

83 134 0

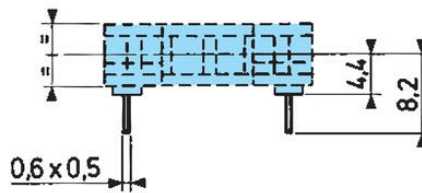
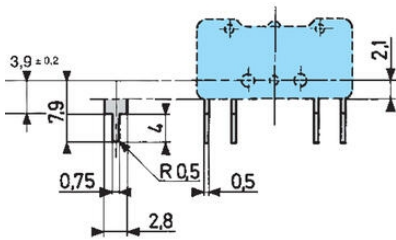
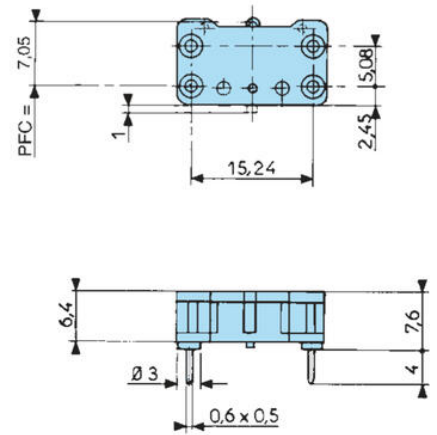

54B

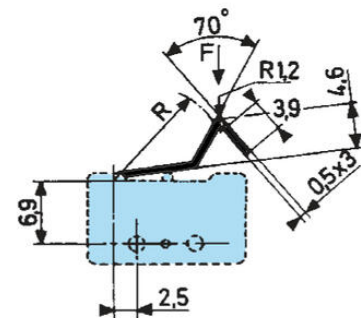

54A2

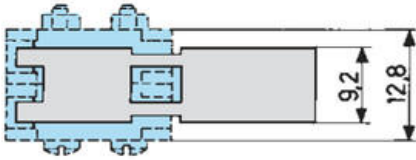
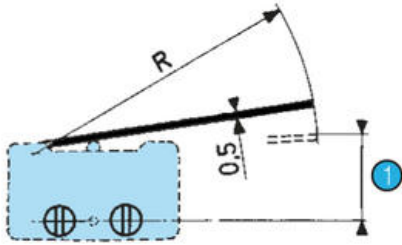

1 Switching point

54A3

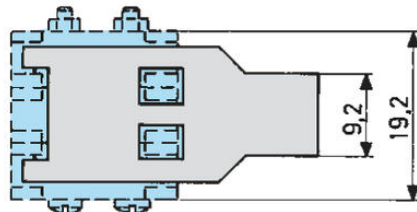

For 83 132 0 och 83 133 0

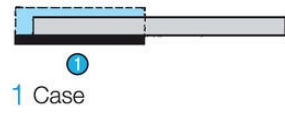

For 83 134 0

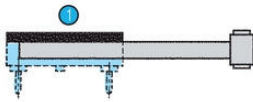

1 Case