



POWER SUPPLY 1-PHASE, 12 V DC DIMENSION Q SERIES

QS10.121

PSU 100-240V ac I/P 12V dc 15A 180W O/P

- Output current of 15 A
- Up to 92% efficiency
- Only 60 mm wide
- 100-240 VAC / 88-370 VDC



PRODUCT DESCRIPTION

The most outstanding features of this Dimension Q Series DIN-rail power supply are the high efficiency and the small size, which are achieved by a synchronous rectification and further novel design details. The Q Series is part of the Dimension family, existing alongside the lower featured C-Series. With short-term peak power capability of 150% and built-in large sized output capacitors, these features help start motors, charge capacitors and absorb reverse energy and often allow a unit of a lower wattage class to be used.

High immunity to transients and power surges as well as low electromagnetic emission makes usage in nearly every environment possible.

The integrated output power manager, a wide range input voltage design and virtually no input inrush current make installation and usage simple.

Diagnostics are easy due to the dry DC-ok contact, a green DC-ok LED and red overload LED.

Unique quick-connect spring-clamp terminals allow a safe and fast installation and a large international approval package for a variety of applications makes this unit suitable for nearly every situation.

For a good cooling, we recommend a clearance of 40 mm over 20 mm below. We recommend 5 mm air gap to the sides (15 mm on the sides of adjacent product is a heat source).

Output characteristics

SPECIFICATIONS

Active Transient	Yes
Approvals	ABS, CB, CE, CSA, GL, UL
DC relay output	Yes
Depth	117
Effect	180
Efficiency At 120 V AC, full load. Typical	91.5
Efficiency At 230 V AC, full load. Typical	91.8

Efficiency At 230 V AC. Typical	90.6
Height	124
Hold-up time at 120 V AC, full load. Typical.	32
Hold-up time at 230 V AC, full load. Typical.	32
Input voltage AC	100-240 V
Input voltage ac max	276
Input voltage ac min	85
Input voltage DC	110-150 V
Input voltage dc max	187
Input voltage dc min	88
Input voltage range	Wide-range
Inrush current at 120 V ac typical	4
Inrush current at 230 V ac typical	7
IP Class	IP20
Lifetime at 120 V ac, full load and +40 ° C	65000
Lifetime at 230 V ac, full load and +40 ° C	76000
MTBF (IEC 61709) 230 V AC, Maximum Load, 40 ° C	631000
Number of phases	1
Output Current	15
Output voltage	12
Output voltage max	15
Output voltage min	12
Power Consumption At 120 V AC	1.65
Power Consumption At 230 V AC	0.93
Power Factor at 120 V AC, full load. Typical	0.98
Power Factor at 230 V AC, full load. Typical	0.92
Power Reduction Of 60 To 70 ° C	5
Ripple. max	50
Series	Dimension Q
Supply Frequency	50-60 ±6 %
Temperature Range Without Derating From	-25
Temperature Range Without Derating To	60
Weight	0.9
Width	60

Fig. 6-1 Output voltage vs. output current, typ.

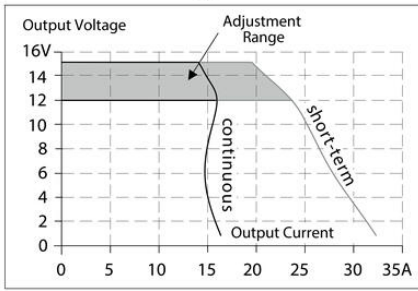

Fig. 15-1 Output current vs. ambient temp.

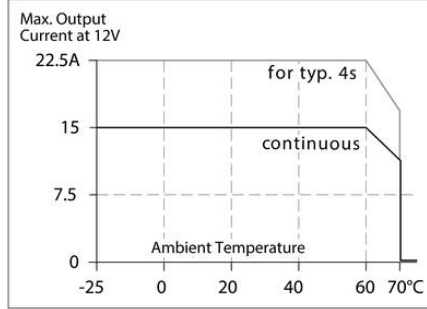

Fig. 9-2 Losses vs. output current at 12V, typ.

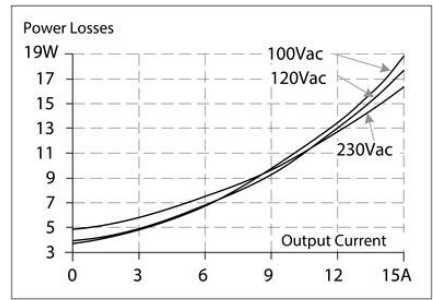

Fig. 9-1 Efficiency vs. output current at 12V, typ.

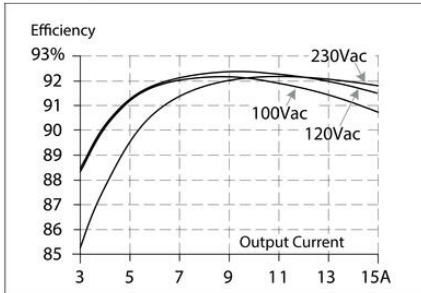
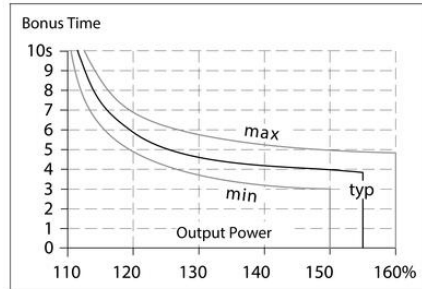

Fig. 6-2 Bonus time vs. output power



Maximal wire length *) for a fast (magnetic) tripping:

	0.75mm ²	1.0mm ²	1.5mm ²	2.5mm ²
C-2A	11m	15m	22m	35m
C-3A	10m	13m	19m	31m
C-4A	5m	8m	11m	16m
C-6A	1m	2m	3m	5m
B-6A	6m	8m	12m	18m
B-10A	2m	2m	3m	5m
B-13A	1m	1m	2m	4m

*) Don't forget to consider twice the distance to the load (or cable length) when calculating the total wire length (+ and - wire).

Fig. 13-1 Front side



Fig. 20-1 Front view

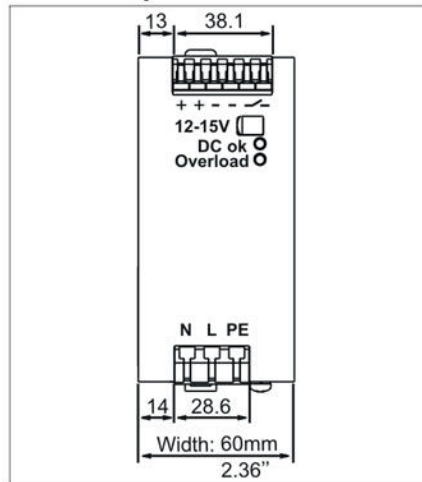

Fig. 20-2 Side view

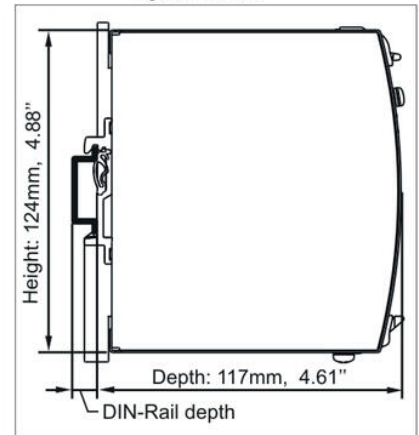

Fig. 6-1 Output voltage vs. output current, typ.

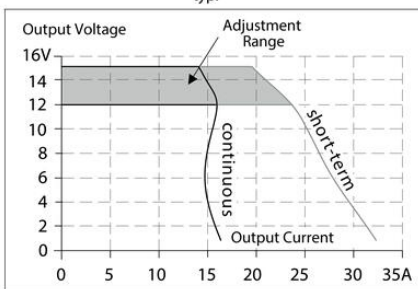

Fig. 15-1 Output current vs. ambient temp.

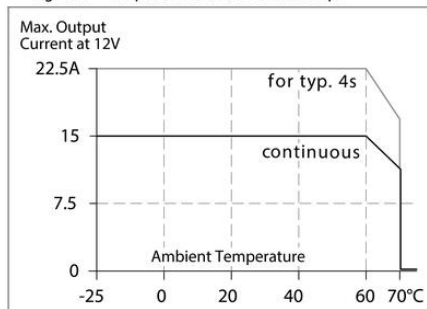

Fig. 9-2 Losses vs. output current at 12V, typ.

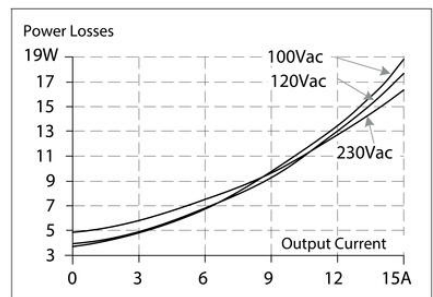

Fig. 9-1 Efficiency vs. output current at 12V, typ.

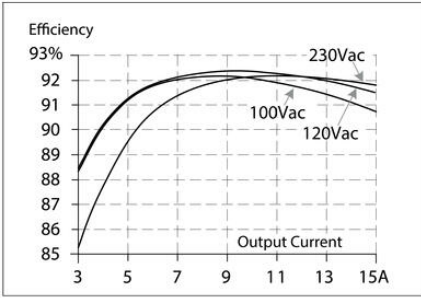
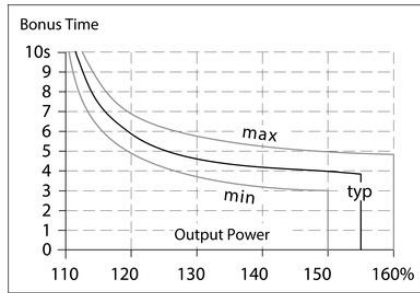

Fig. 6-2 Bonus time vs. output power



Maximal wire length *) for a fast (magnetic) tripping:

	0.75mm ²	1.0mm ²	1.5mm ²	2.5mm ²
C-2A	11m	15m	22m	35m
C-3A	10m	13m	19m	31m
C-4A	5m	8m	11m	16m
C-6A	1m	2m	3m	5m
B-6A	6m	8m	12m	18m
B-10A	2m	2m	3m	5m
B-13A	1m	1m	2m	4m

*) Don't forget to consider twice the distance to the load (or cable length) when calculating the total wire length (+ and - wire).

Fig. 13-1 Front side



Fig. 20-1 Front view

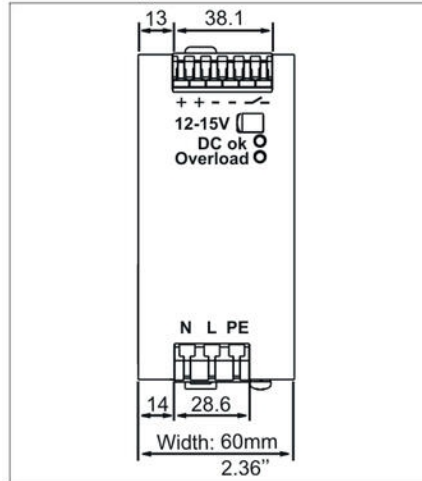

Fig. 20-2 Side view

